

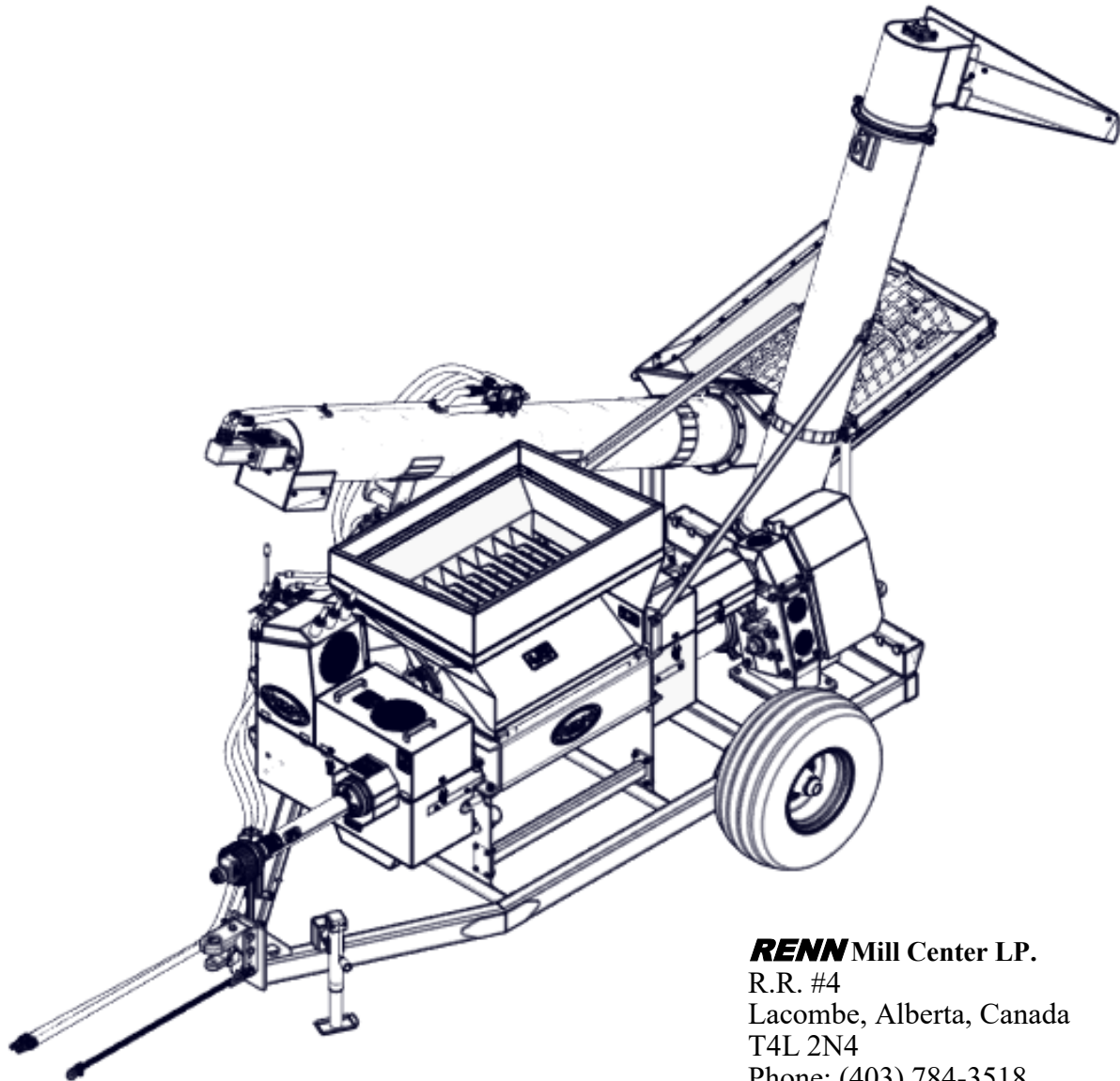

**RMC 36-A With Diff  
Operator's & Parts Manual  
P.T.O.  
Model No. 973600-0026.00**



**RENN** Mill Center LP.  
R.R. #4  
Lacombe, Alberta, Canada  
T4L 2N4  
Phone: (403) 784-3518  
Fax : (403) 784-2060  
Email : [rennmill@rennmill.com](mailto:rennmill@rennmill.com)  
[www.rennmill.com](http://www.rennmill.com)

# TABLE OF CONTENTS

---

<b>TABLE OF CONTENTS.....</b>	<b>1.1</b>
<b>INTRODUCTION .....</b>	<b>1.3</b>
<b>RENN WARRANTY POLICY .....</b>	<b>1.4</b>
<b>MILL SERIAL NUMBER LOCATION.....</b>	<b>1.5</b>
<b>2 SAFETY.....</b>	<b>2.1</b>
2.1 GENERAL SAFETY .....	2.2
2.2 OPERATING SAFETY .....	2.3
2.3 MAINTENANCE SAFETY .....	2.3
2.4 HYDRAULIC SAFETY .....	2.4
2.5 STORAGE SAFETY .....	2.4
2.6 SAFETY DECALS .....	2.4
2.7 SAFETY SHIELD PLACEMENT .....	2.5
2.8 SIGN-OFF FORM .....	2.7
<b>3 DECAL LOCATIONS.....</b>	<b>3.1</b>
3.1 SAFETY DECAL LOCATIONS.....	3.1
3.2 INFORMATION DECAL LOCATIONS.....	3.3
<b>4 OPERATION.....</b>	<b>4.1</b>
4.1 TO THE NEW OPERATOR OR OWNER.....	4.1
4.2 BEFORE YOU BEGIN .....	4.1
4.3 PRE-OPERATIONAL CHECKLIST .....	4.1
4.4 SETTING UP THE ROLLER MILL.....	4.2
4.4.1 ROLL SETTING.....	4.2
4.4.2 ROLL GAP ADJUSTMENT .....	4.3
4.4.3 FEED GATE CONTROL .....	4.4
4.4.4 SETTING WEAR PLATES.....	4.4
4.4.5 CROSS AUGER BELT TENSION .....	4.4
4.4.6 ROLL DRIVE BELT TENSION.....	4.5
4.4.7 SPRING PRESSURE .....	4.5
4.4.8 GRATE MAGNET.....	4.6
4.4.9 AUGER SET UP .....	4.6
4.5 OPERATING THE ROLLER MILL .....	4.7
4.6 ROLLER MILL BREAK-IN .....	4.9
4.7 REDUCTION GEARBOX.....	4.10
4.8 REDUCTION GEARBOX REPLACEMENT .....	4.10
<b>5 SERVICE AND MAINTENANCE.....</b>	<b>5.1</b>
5.1 SERVICING RECORD .....	5.1
5.2 SERVICING INTERVALS.....	5.2
5.3 REMOVAL OF ROLLS FOR SERVICING .....	5.5
5.4 REDUCTION GEARBOX SERVICING.....	5.6
5.5 REDUCTION GEARBOX REPLACEMENT .....	5.7
<b>6 PDI SETUP.....</b>	<b>6.1</b>
<b>7 TRANSPORTATION .....</b>	<b>7.1</b>
<b>8 STORAGE.....</b>	<b>8.1</b>
8.1 PLACING IN STORAGE .....	8.1
8.2 REMOVING FROM STORAGE & PRE-SEASON PREPARATION .....	8.1

# TABLE OF CONTENTS

---

<b>9</b>	<b>TROUBLESHOOTING GUIDE .....</b>	<b>9.1</b>
<b>10</b>	<b>SPECIFICATIONS .....</b>	<b>10.1</b>
10.1	GENERAL SPECIFICATIONS.....	10.1
10.2	TIRE SPECIFICATIONS .....	10.1
10.3	BOLT TORQUE SPECIFICATIONS.....	10.1
10.4	OVERALL DIMENSIONS.....	10.3
<b>11</b>	<b>PARTS.....</b>	<b>11.1</b>
11.1	TOP HOPPER .....	11.1
11.1.1	TOP HOPPER (KNOB) .....	11.3
11.2	IDLER ATTACHMENT .....	11.4
11.3	ROLLER MILL - UPPER HALF .....	11.6
11.4	WORM DRIVE ROLL ADJUSTMENT.....	11.8
11.5	MULTI-BELT DIFFERENTIAL DRIVE & SHIELD - FRONT.....	11.10
11.6	MULTI-BELT DIFFERENTIAL DRIVE - REAR.....	11.12
11.7	MULTI-BELT DIFFERENTIAL SHIELD - REAR.....	11.14
11.8	BOTTOM HOPPER .....	11.16
11.9	CROSS AUGER ASSEMBLY .....	11.18
11.10	DRIVE BOX .....	11.20
11.10.1	DRIVE BOX ASSEMBLY .....	11.22
11.11	TRAILER ASSEMBLY .....	11.24
11.11.1	HUB ASSEMBLY (340800-0812) .....	11.26
11.12	DISCHARGE AUGER .....	11.27
11.12.1	TUBE & FLIGHTING .....	11.27
11.12.2	GEAR BOX .....	11.29
11.13	TRANSFER AUGER .....	11.31
11.13.1	LIFT AND SWING PEDESTAL .....	11.31
11.13.2	UPPER SECTION .....	11.33
11.13.3	HOPPER BODY.....	11.35
11.14	TRANSFER AUGER HYDRAULICS .....	11.37
11.14.1	TRANSFER AUGER HYDRAULICS - LIFT .....	11.37
11.14.2	TRANSFER AUGER HYDRAULICS - DRIVE.....	11.38
11.15	ROLL BUSHING ASSEMBLY - B-LOC BUSHING .....	11.40
<b>12</b>	<b>NOTES SHEET .....</b>	<b>12.1</b>

# INTRODUCTION

---

Congratulations on your decision to purchase a Renn Auxiliary Mill. This machine has been designed to provide you with the highest standards of quality, reliability and durability. This manual has been prepared to familiarize you with the operation and maintenance of your mill. We urge you to read the publication carefully and refer to it extensively for correct operating procedure.

The Renn Auxiliary Mill is designed to give the operator a maximum capacity and working surface through the use of a large diameter roll. Added to this is a convenient method of roll removal and a new process of roll adjustment, giving the operator infinite control of feed quality. The auxiliary option included with this mill enhances the variety of applications beyond those of the standard mill to include bagging, blowing, and any other secondary application requiring input power. This mill is constructed in a solid manner, giving you value for your dollar and a mill that will last.

This manual includes a Warranty Policy, a Safety Section, and a Lubrication and Maintenance Schedule. We urge you to read through this information carefully as it will help to ensure the safe and trouble-free operation of your mill. All information, illustrations and specifications in this manual are based on the latest product information available. We, the manufacturer, reserve the right to make any changes at any time without prior notice.

# LIMITED WARRANTY



## • NEW EQUIPMENT WARRANTY

Subject to the limitations and exclusions set out herein, RENN Mill Center LP. ("Renn") warrants that if any component or part of a machine manufactured by Renn proves to be defective in material or workmanship within

1. (1) year from the delivery date of the original sale to a purchaser who purchases the equipment for their own farming operation use; OR
2. (90) days from the delivery date of the original sale to any other purchaser.

Renn will at Renn's option either repair or replace the defective part without charge. No payments will be made in lieu of repair to the machine. This limited warranty may be enforced by the first purchaser or first consumer user; all subsequent purchasers acquire the product "as is" without any benefit of this limited warranty.

## • LIMITATIONS AND EXCLUSIONS

This limited warranty by Renn does not extend to or include:

1. New tires - installed on the equipment which are subject to a separate warranty by the tire manufacturer—see warranty sheet included with your owners manual. All warranty claims must be submitted to the tire manufacturer for approval and payment.
2. Used tires
3. Drive Belts
4. Drive Chains

This limited warranty covers defects in material and workmanship in the parts manufactured by Renn except:

1. Damage resulting from accident, misuse, abuse, neglect or from other than normal and ordinary use of the equipment.
2. Damage resulting from failure to clean or use the product in accordance with the manufacturer's instructions.
3. Renn reserves the manufacturer's right to determine the responsibility for damage as detailed in 1 and 2 above.

Renn shall, as to each defect, be released from all obligations and liabilities under this warranty if:

1. The equipment shall have been operated with any accessory, equipment, component or part not manufactured by Renn or not approved for use by Renn.
2. The equipment shall have been repaired, altered or modified without Renn's approval or if the equipment shall have been operated subsequent to its involvement in an accident or breakdown unless the purchaser furnishes reasonable evidence that such repair, modification or operation subsequent to its involvement in an accident or breakdown was not the cause of the defect;
3. If the purchaser or consumer does not, within 30 days from the date of discovery of the defect, return the defective machine, accessory, equipment component or part at the purchaser's or users expense to an authorized dealer, purchaser shall be responsible for submission of reasonable evidence or proof of date of discovery of subsequent defect.

## • WARRANTY AND PARTS REPLACED BY WARRANTY

Renn further warrants that if any genuine Renn part or component utilized by authorized Renn dealers in accordance with this limited warranty proves to be defective in material or workmanship within 90 days of such utilization, Renn will, at Renn's option either repair or replace the defective part without charge. Purchaser shall be responsible for any shipping charges including freight to and from the place where the warranty work is done or performed.

## • WHAT YOU MUST DO TO ENFORCE THIS WARRANTY

1. Warranty services must be performed by a dealer authorized by Renn. The purchaser must, at the purchaser's expense, deliver, mail or ship the defective part to any duly authorized dealer in the purchasers area. If the purchaser is unable to locate a dealer in the purchaser's area, please contact Renn. Renn will either refer you to an authorized dealer or instruct you where to return the product. Do not return the product to Renn, without Renn's prior authorization
2. Purchaser must pay any postage, shipping charges, insurance costs, freight and other expenses to and from the place where the warranty work is done or performed if required to return equipment or any component or part to an authorized dealer or as directed by Renn. Purchaser shall be obligated to pay any premium payable for overtime labour if overtime is incurred as a result of a request by the purchaser.

## • UNAPPROVED SERVICE OR MODIFICATION

All obligations of Renn under this warranty shall be terminated:

1. If service is performed by someone other than a dealer authorized by Renn or,
2. If equipment is altered or modified in ways not approved by Renn.

Accidents and normal maintenance

This warranty covers only defective material and workmanship. It does not cover depreciation or damage caused by normal wear, accident, improper maintenance, improper protection in storage or improper use. The cost of normal maintenance and replacement of service items, oil filters, cutting parts, tires, bearings, chains, sprockets or brake parts shall be paid for by the purchaser.

## • NO REPRESENTATION OR IMPLIED WARRANTY

1. Where permitted by law, neither Renn nor any company affiliated with it makes any warranties, representation or promises expressed or implied as to the quality or performance of its products other than those set forth above.
2. Renn makes no warranty of merchantability or fitness for a particular purpose.

## • IMPROVEMENTS OR CHANGES

Renn reserves the right to make improvements or changes in design and specifications at any time without incurring any obligation to owners of previously sold units.

## • WARRANTY CLAIM PROCEDURE

Warranty Claim Form must be delivered to Renn within 60 days after the warranty work was performed. Defective parts must be held for inspection for 90 days after the work was performed. Renn may request that parts be returned to the Renn factory for inspection. If approved, Renn will issue a credit within 60 days of receiving the warranty claim.

## • ACKNOWLEDGEMENT REQUIRED

Renn shall have no obligation under this warranty unless the "Warranty Registration" included with your owners manual signed by purchaser and dealer is delivered to Renn within 30 days from the date of sale.

## IMPORTANT NOTICE

**To activate warranty coverage, the owner / dealer must complete the Warranty Registration form that can be found online and return to Renn Mill Center LP. R.R. 4, Lacombe, Alberta, Canada, T4L 2N4 within 30 days of retail sale.**

## SERIAL NUMBER LOCATION

The serial number plate is located on the inside face of the back panel of the top hopper, on the driver's side of the machine.

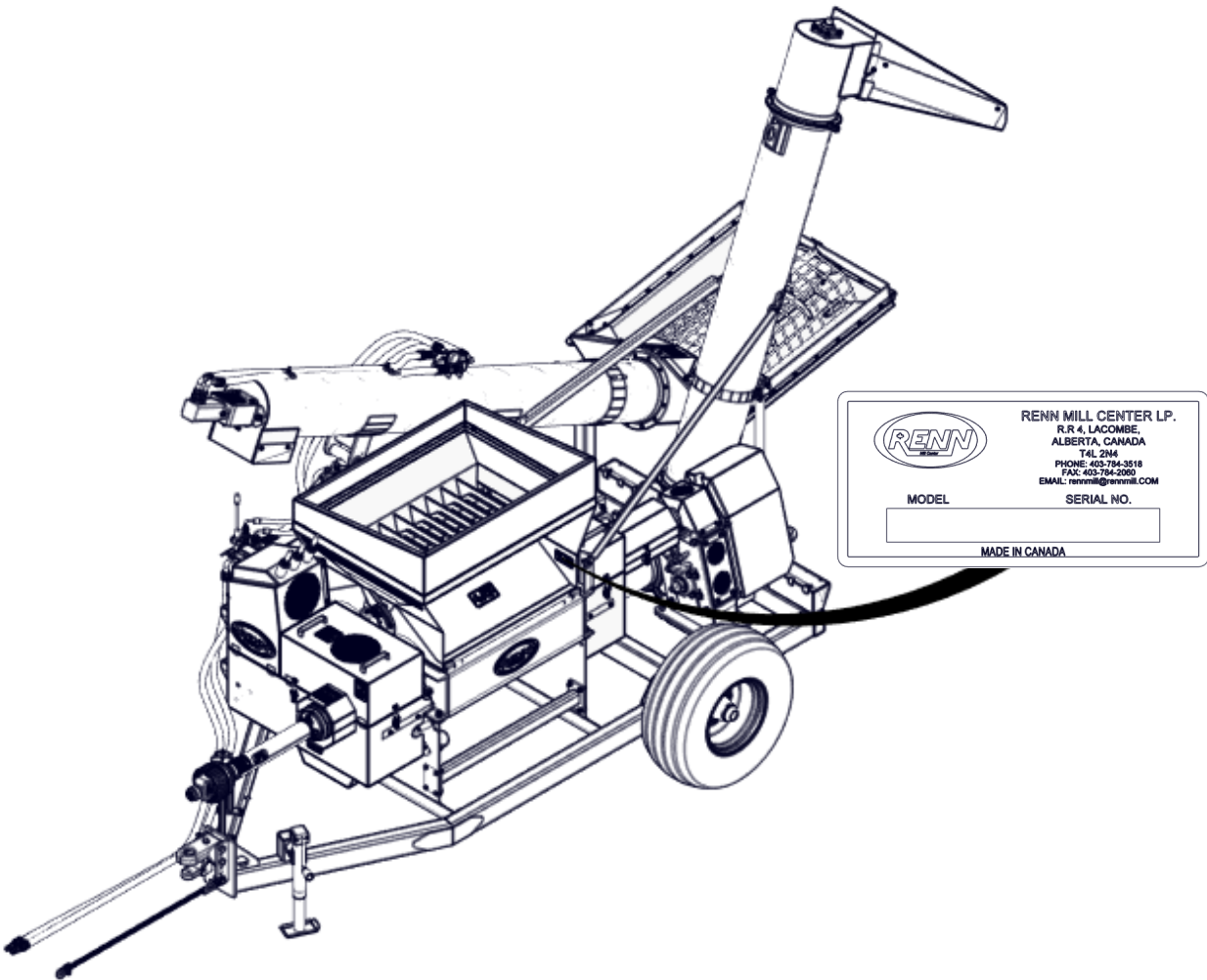

**IMPORTANT:** For fast, correct service when ordering parts, supply the following information to your local Renn Dealer:

- 1) The model number
- 2) The serial number

This information is essential when ordering parts for your Renn Auxiliary Mill.



## 2 SAFETY

---

### Safety Alert Symbol

This Safety Alert symbol means

**ATTENTION!  
BE ALERT!  
YOUR SAFETY IS  
INVOLVED!**



The Safety Alert symbol identifies important safety messages on the Renn Mill and in the manual. When you see this symbol, be alert to the possibility of personal injury or death. Follow the instructions in the safety message.

Why is SAFETY important to you?

#### 3 Big Reasons

#### Accidents Disable and Kill

#### Accidents Cost

#### Accidents Can Be Avoided

#### SIGNAL WORDS:

Note the use of the signal words **DANGER**, **WARNING**, and **CAUTION** with the safety messages. The appropriate signal word for each message has been selected using the following guidelines:

#### **DANGER -**

Indicates an imminently hazardous situation that, if not avoided, will result in death or serious injury. This signal word is to be limited to the most extreme situations, typically for machine components that, for functional purposes, cannot be guarded.

#### **WARNING -**

Indicates a potentially hazardous situation that, if not avoided, could result in death or serious injury, and includes hazards that are exposed when guards are removed. It may also be used to alert against unsafe practices.

#### **CAUTION -**

Indicates a potentially hazardous situation that, if not avoided, may result in minor or moderate injury. It may also be used to alert against unsafe practices.

## 2 SAFETY

---



You are responsible for the SAFE operation and maintenance of your Renn Auxiliary Mill. YOU must ensure that you and anyone else who is going to operate, maintain or work around the mill be familiar with the operating and maintenance procedures and related SAFETY information contained in this manual. This manual will take you step-by-step through your working day and will alert you to all good safety practices that should be adhered to while operating the mill.

Remember, YOU are the key to safety. Good safety practices not only protect you but also the people around you. Make these practices a working part of your safety program. Be certain that EVERYONE operating this equipment is familiar with the recommended operating and maintenance procedures and follows all of the safety precautions. Most accidents can be prevented. Do not risk injury or death by ignoring good safety practices.

- Mill owners must give operating instructions to operators or employees before allowing them to operate the mill, and at least annually thereafter per OSHA regulation 1928.57.
- The most important safety device on this equipment is a SAFE operator. It is the operator's responsibility to read and understand ALL Safety and Operating instructions in the manual and to follow them. All accidents can be avoided.
- A person who has not read and understood all operating and safety instructions is not qualified to operate the machine. An untrained operator exposes himself and bystanders to possible serious injury or death.
- Do not modify the equipment in any way. Unauthorized modification may impair the function and/or safety and could affect the life of the equipment.
- Think SAFETY! Work SAFELY!

### **2.1 General Safety**

1. Only trained, competent persons should operate the mill. An untrained operator is not qualified to operate the machine.
2. Have a first-aid kit available for use, should the need arise, and know how to use it.
3. Have a fire extinguisher available for use, should the need arise, and know how to use it.
4. Wear appropriate protective gear. This list includes but is not limited to:
  - A hard hat
  - Protective shoes with slip resistant soles
  - Protective goggles
  - Hearing protection
5. Review safety related items annually with all personnel.



## 2 SAFETY

---



### **2.2 Operating Safety**

1. Read and understand the Operator's Manual and all safety signs before using the machine.
2. Keep hands, feet, hair and clothing away from all moving and/or rotating parts.
3. Do not allow riders on the mill or tractor during operation or transportation.
4. Clear the area of all bystanders, especially children, before starting.
5. Be aware of overhead power lines at all times.
6. Attach any necessary flags and signs to the mill before transporting.
7. Attach securely to the towing unit using a hardened pin with a retainer and a safety chain. The pin should be the maximum allowable size possible.
8. The mill is designed to mill GRAIN. It is not suggested to use the mill for other materials without receiving consent from the factory to do so. Failure to heed this warning will result in forfeiture of warranty.
9. Ensure that there is adequate lighting when operating at night.
10. Use caution while using machine on uneven terrain.
11. Never unhook the mill while it is in use.
12. Review safety instructions annually.

### **2.3 Maintenance Safety**

1. Place all controls in neutral, stop the engine, set the parking brake, remove the ignition key, wait for all moving parts to stop and disengage the PTO before servicing, adjusting, repairing or unplugging.
2. Perform a lock out tag out (LOTO) procedure if required.
3. Relieve pressure from the hydraulic circuit before servicing or disconnecting from the tractor.
4. Place stands or blocks under the frame before working beneath the machine or when changing tires.
5. Only use tools, jacks and hoists appropriate for the job.
6. Install and secure all guards and shields before resuming operation.

## 2 SAFETY

---



### **2.4 Hydraulic Safety**

1. Always place all hydraulic controls in neutral before dismounting.
2. Make sure that all components in the hydraulic system are kept in good condition. Replace any worn, cut, abraded, flattened or crimped hoses.
3. Wear proper hand and eye protection when searching for a high pressure hydraulic leak. Use a piece of wood or cardboard, rather than your hands, as a shield to isolate and identify a leak.
4. If injured, seek medical attention immediately. Serious infection or reaction can develop from hydraulic fluid piercing the skin.
5. Before pressurizing the system, make sure that all components are tight and that hoses, fittings and couplings are in good condition.

### **2.5 Storage Safety**

1. Store the unit in an area away from human activity.
2. Do not permit children to play on or around the stored mill.

### **2.6 Safety Decals**

1. Keep safety decals clean and legible at all times.
2. Replace safety decals that are missing or have become illegible.
3. Replaced parts that displayed a safety decal should also display the same decal.
4. Safety decals are available through your authorized Renn Dealer.

## 2 SAFETY



### 2.7 Safety Shield Placement

After servicing or maintenance, these shields should be back in place.

PTO/Front Bearing and Cam Shield

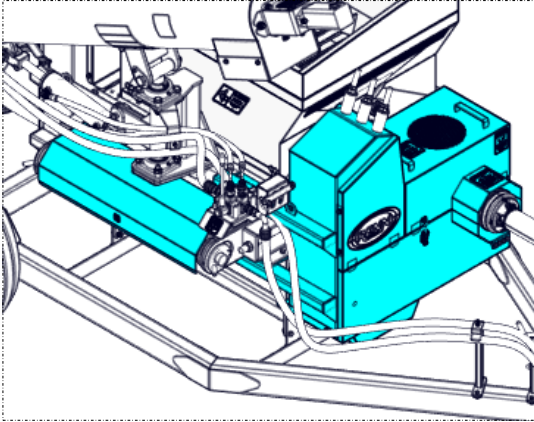

Inspection Plate

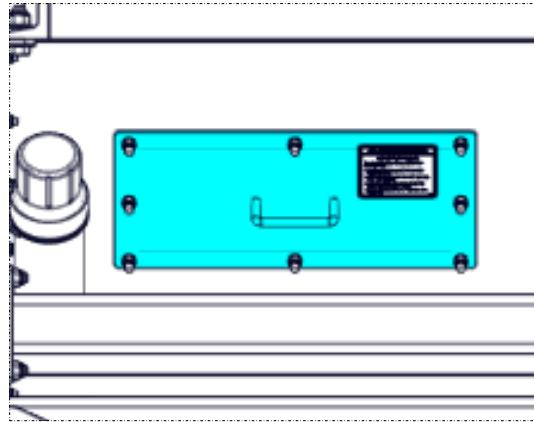

Rear Shield, Belt Reduction Shield  
& gearbox door Shield

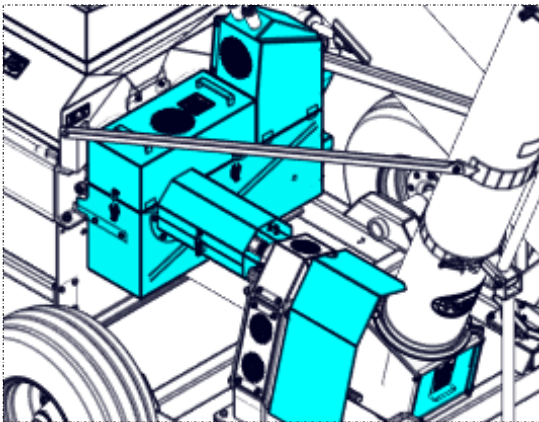

Transfer Auger mesh

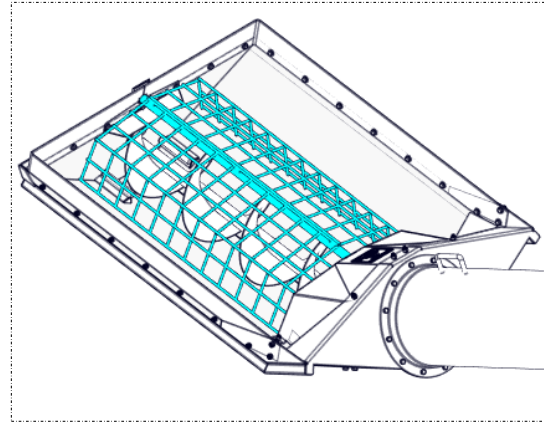

PTO: Front and Rear Covers

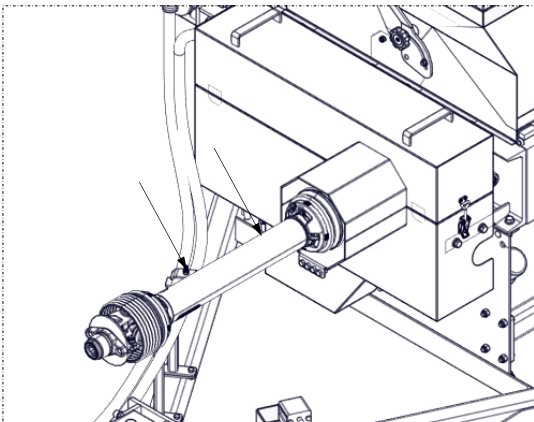

Transfer auger gearbox shield

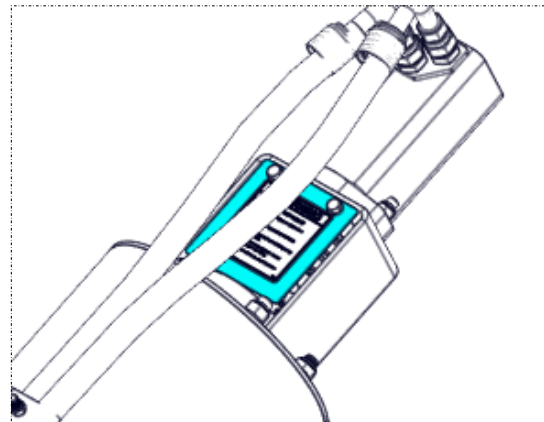

## 2 SAFETY

---



### **2.7 Safety Shield Placement (Cont'd)**

After servicing or maintenance, these shields should be back in place.

Feed Auger Motor Shield - Front

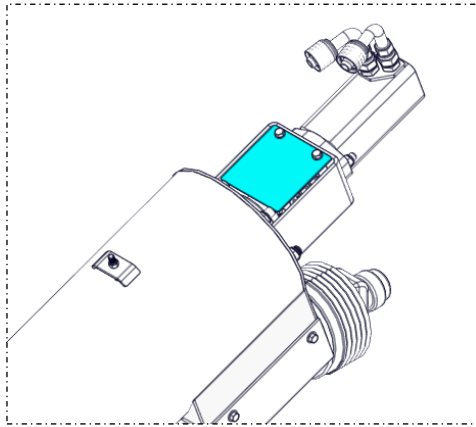

Feed Auger Motor Shield - Rear

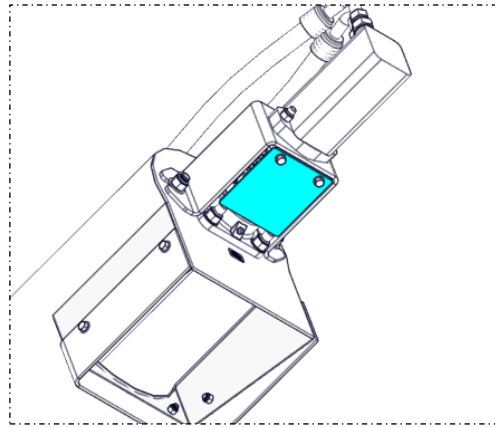

## 2 SAFETY

---



### **2.8 Sign-off Form**

Anyone operating and/or maintaining the mill must read and clearly understand ALL of the Safety, Operating, and Maintenance information presented in this manual.

Do not operate or allow anyone else to operate this equipment until such information has been reviewed. Review this information annually, before the season start-up.

Make these periodic reviews of SAFETY and OPERATION a standard practice for all of your equipment. We feel that an untrained operator is unqualified to operate this machine. A sign-off sheet is provided for your record keeping to show that all personnel who will be working with the equipment have read and understood the information in the Operator's Manual and have been instructed in the operation of the equipment.

### **Sign-off Form**

<i>DATE</i>	<i>EMPLOYEE SIGNATURE</i>	<i>EMPLOYER SIGNATURE</i>

## 3 DECAL LOCATIONS

### 3.1 Safety Decal Locations

The types of safety decals and locations on the equipment are shown in the following illustrations. Good safety requires that you familiarize yourself with the various safety decals, the type of warning and the area, or particular function related to that area, that requires your SAFETY AWARENESS.

- THINK SAFETY!!, WORK SAFELY!!



148000-0105



148000-0166



148000-0406



148000-0700



148100-0005



148900-0067



148000-0102



148000-0103

REMEMBER - If safety decals have been damaged, removed, or become illegible, or if parts that have been replaced which previously displayed safety decals do not currently contain safety decals, new decals must be applied. New safety decals are available from your authorized dealer.

# 3 DECAL LOCATIONS

## 3.1 Safety Decal Locations

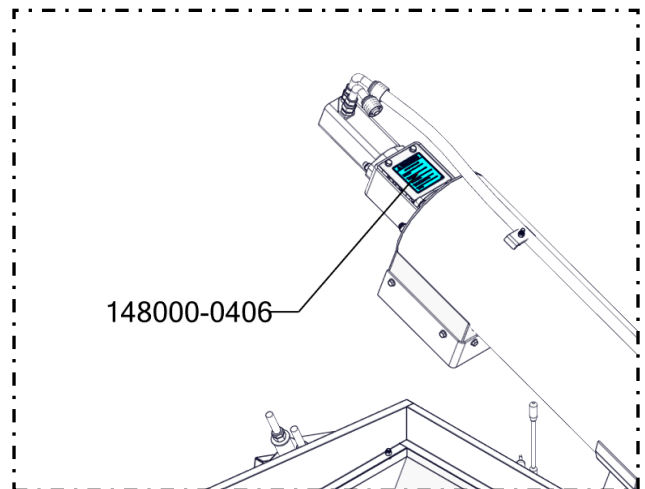
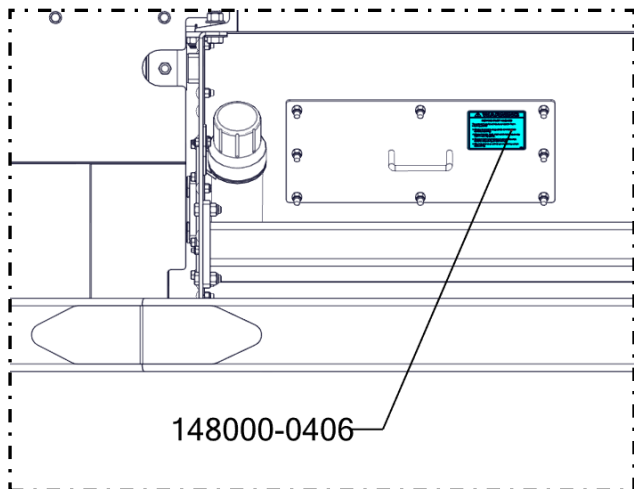
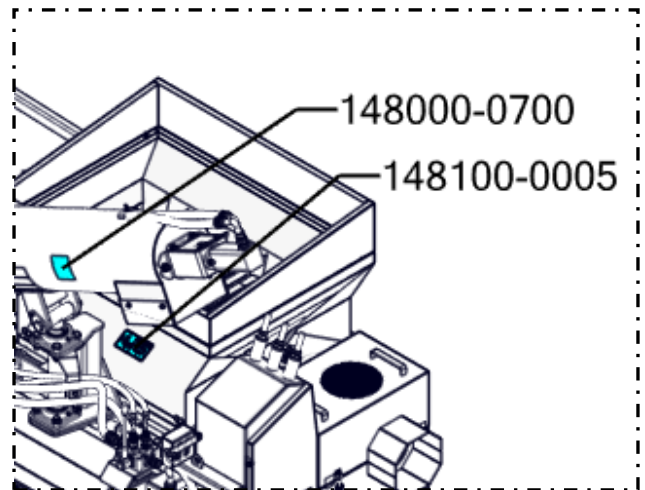
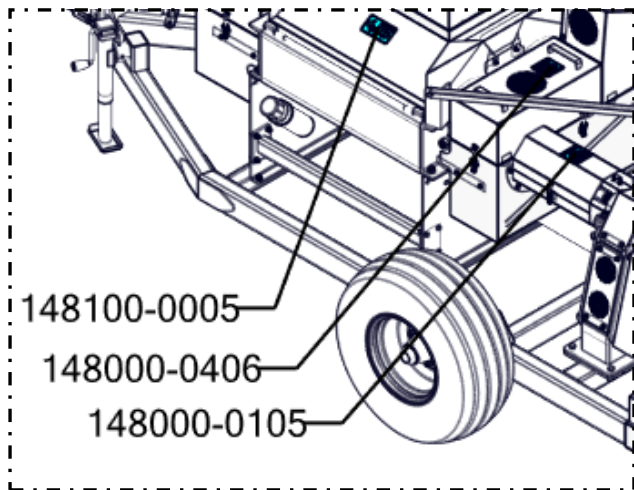
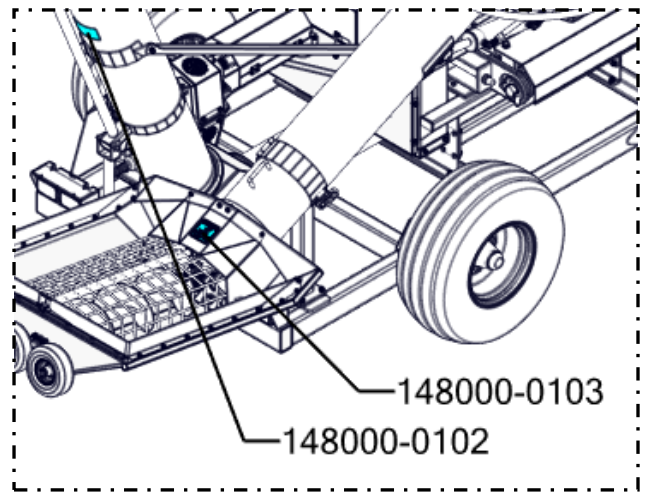
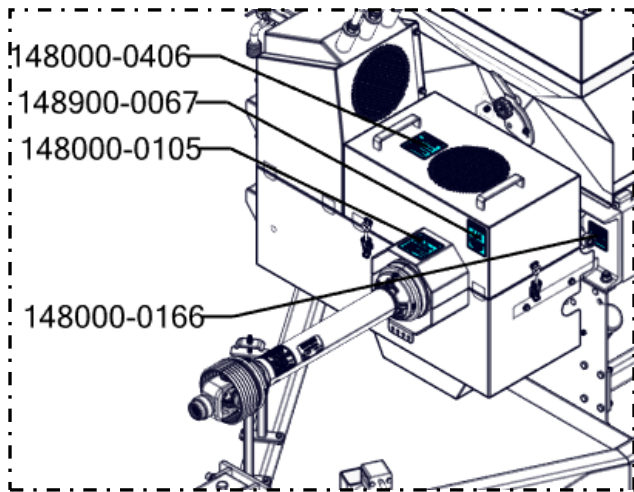

## 3 DECAL LOCATIONS

### 3.2 Information Decal Locations

The types of informational and operational decals and locations on the equipment are shown in the following illustrations. Good operation requires that you familiarize yourself with the various operational decals, the type of warning and the area, or particular function related to that area, that requires your AWARENESS.

- WORK SAFELY!!



148700-0036



148700-0051



148100-0100



148800-0112



148800-0200



148000-0012



148800-0070



414000-0803



148100-0010



148800-0202



# 3 DECAL LOCATIONS

## 3.2 Information Decal Locations

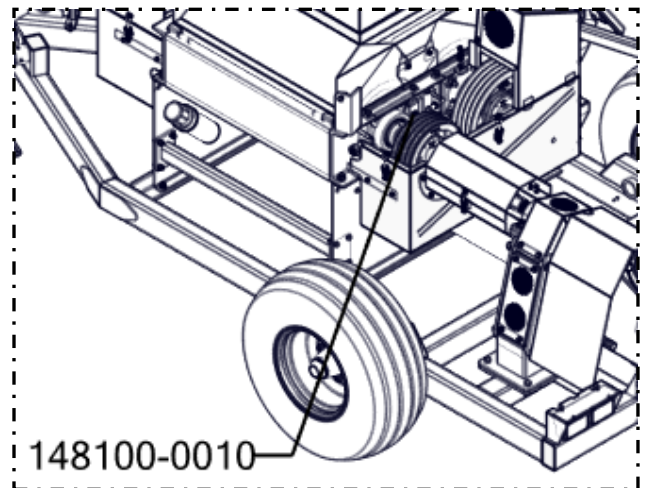
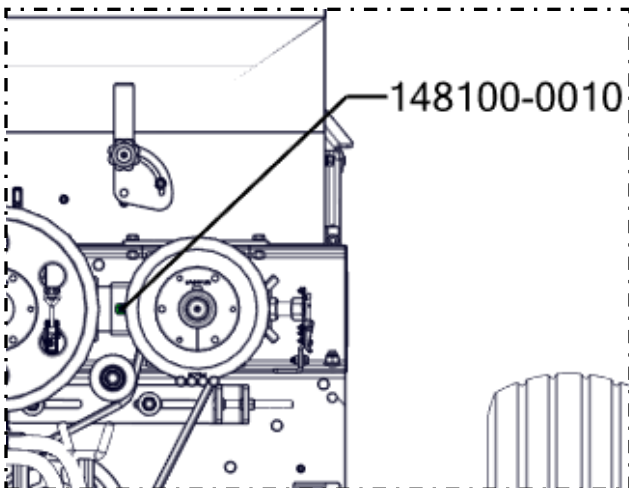
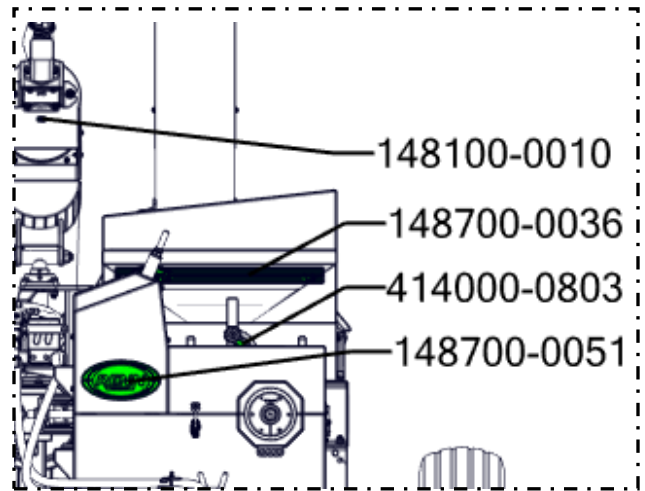
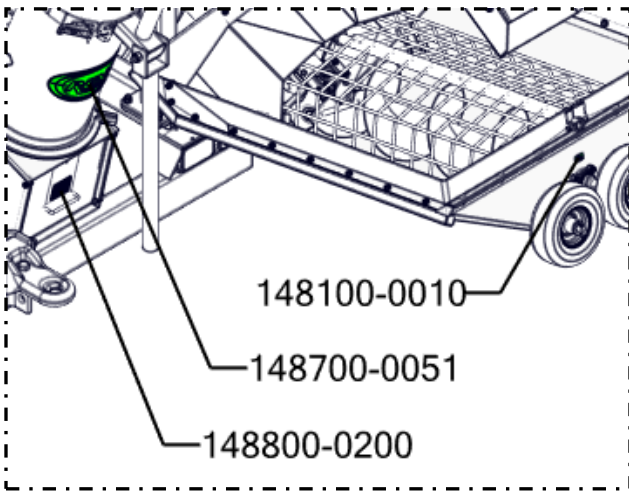
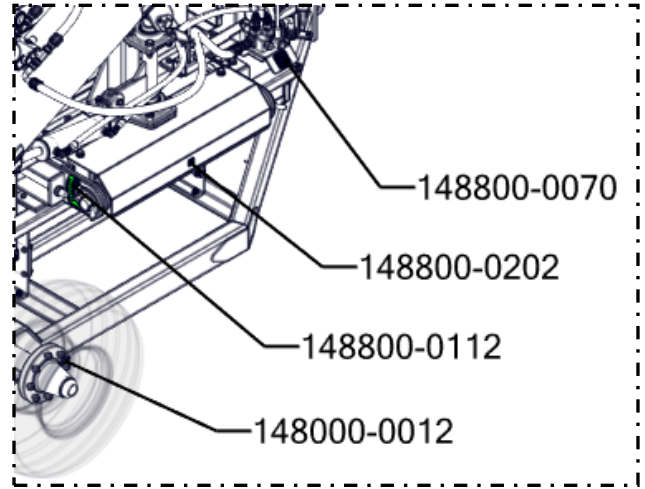
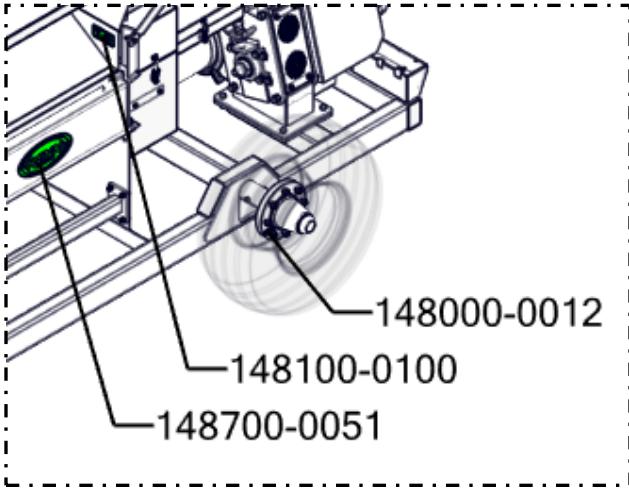

## **4 OPERATION**

---

### **4.1 To the New Operator or Owner**

The Renn Mill is designed to receive dry grain from an auger, process it, and deposit it via the discharge auger. Be familiar with the machine before starting.

In addition to the design and configuration of equipment, hazard control and accident prevention are dependent upon the awareness, concern, and prudence of personnel involved in the operation, transportation, maintenance and storage of equipment and in the use and maintenance of facilities.

It is the responsibility of the owner or operator to read this manual and to train all other operators before they start working with the machine. Follow all safety instructions exactly. Safety is everyone's business. By following recommended procedures, a safe working environment is provided for the operator, bystanders and the area around the work site. Untrained operators are not qualified to operate the machine.

Many features incorporated into this machine are the result of suggestions made by customers like you. Read this manual carefully to learn how to operate the machine safely and efficiently. By following the operating instructions in conjunction with a good maintenance program, your roller mill will provide you with many years of trouble-free service.

For more information, please refer to Section 2, 3 & 5 for further maintenance directions.

### **4.2 Before You Begin**

Read the set-up instructions completely. Decide in advance where and how much you're going to roll, and how you plan to unload the grain from the roller mill. Thinking through the process can prevent panic and frustration later. Set up your roller mill before you need it, not when you need it. Do a small trial run if this is your first time using the machine or the process.

### **4.3 Pre-Operational Checklist**

The efficient and safe operation of the Renn Roller Mill requires that each operator read and understand the operating procedures and all related safety precautions outlined in this section. A pre-operational checklist is provided for the operator. It is important for both personal safety and maintaining the good mechanical condition of the mill that this checklist be followed.

Before operating the mill and each time thereafter, the following areas should be checked:

1. Inspect the machine if it is the start of the season as per section 8.2.
2. Lubricate the machine per the schedule outlined in the Maintenance Section (section 5).
3. Be sure that the machine is properly attached to the tractor. Be sure that a mechanical retainer is installed through the drawbar pin and the safety chain is installed.
4. Adjust the hitch position to level the mill with the tractor.
5. Inspect all hydraulic lines, fittings and couplers.
6. Check all bearing locking collars to ensure that they are tight on the shafts and in good condition. Check that all set screws on the bearing collars are tight. Check that all bearing mounting hardware is secure.
7. Make sure all safety shields are properly installed.

## 4 OPERATION

### 4.4 Setting up the Roller Mill

#### 4.4.1 Roll Setting

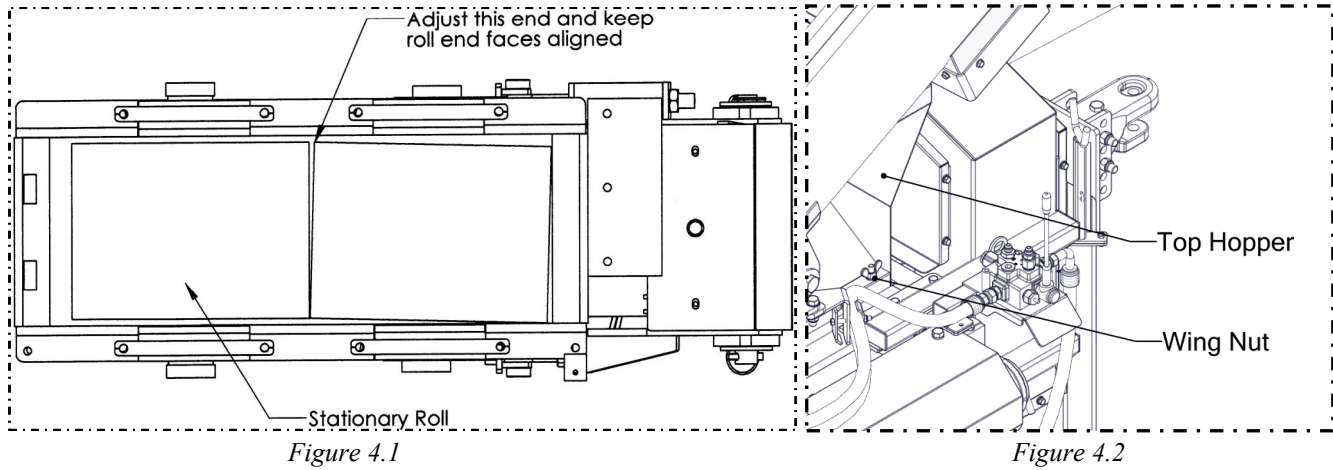

Loosen the wing nuts holding down the top hopper (Figure 4.2) and tip it over center, rotating on the hinge pin until it hits the stoppers.

If using flat rolls to roll dry grain, set the rolls a very small distance apart. Using a sheet of lined paper or feeler gauge, sweep from end to end as you reduce the gap on each end of the roll using the cam linkage adjustment nut (Figure 4.3). Ensure that the positional indicator on the spring cam is in position 1 (Figure 4.3). Turn the adjustment nuts in 1/2 turn segments (less as you near the goal) to adjust the bearing as required. Continue to adjust the roll until some resistance is felt on the paper or feeler gauge.

Turn the roll by hand to confirm that the roll has clearance all the way around. When adjustments are complete, set the jam nuts. Replace the top hopper.

For grooved rolls, the gap may vary based on the required final product. The process for this is the same but with a thicker piece of paper (or multiple pieces) or a feeler gauge.

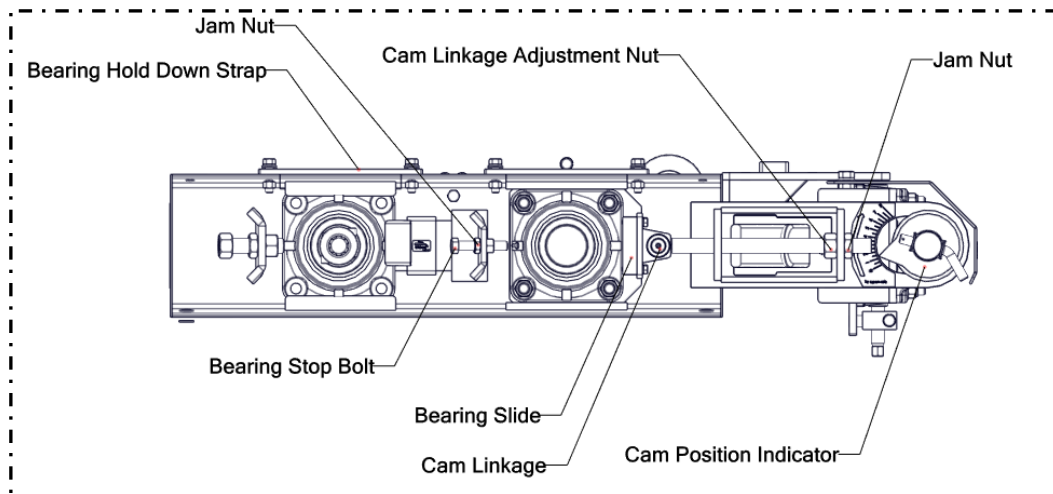

Figure 4.3

## 4 OPERATION

### 4.4.2 Roll Gap Adjustment

The cam control ( Figure 4.4) serves as a mechanism to make roll gap adjustments accurately and quickly using a 3/4" wrench or socket. The cam positional indicator is set at the factory to the "1" position with 5 thousandths of clearance between the rolls. The adjustment nuts are also set at this position to maintain the minimum clearance required to keep the rolls from touching—See 4.4.1 Roll Setting.

To obtain a setting with greater roll gap, rotate the cam control in a clockwise direction after releasing the brake. The brake is released by loosening the brake cross bolt. Rotating the control by more than a half turn at a time is not advised without taking a feed sample. Once the desired setting is obtained, reset the brake to maintain the setting. The cam control may be adjusted while the machine is in operation.

To obtain a setting that delivers a smaller particle size, rotate the cam control in a counter clockwise direction (equates to lower numbers on positional indicator).

To release trapped items, or to unplug the rolls, rotate the cam control so that the positional indicator rotates clockwise and points vertically. Continue turning clockwise until it points horizontally away from the indicated scale.

***This is the maximum gap attainable to release articles caught above the rolls. Larger particles should be removed from above the rolls with the machine powered down. Return the indicator to the former position to resume grinding.***

Additionally, the spring pressure can be increased to control the outcome of the final product. Adjusting the spring pressure is not an exact science and may take some trial and error to achieve the desired results. To adjust the spring pressure, loosen the jam nuts on the spring push bolts and turn the spring bolts in and out until the desired pressure is reached.

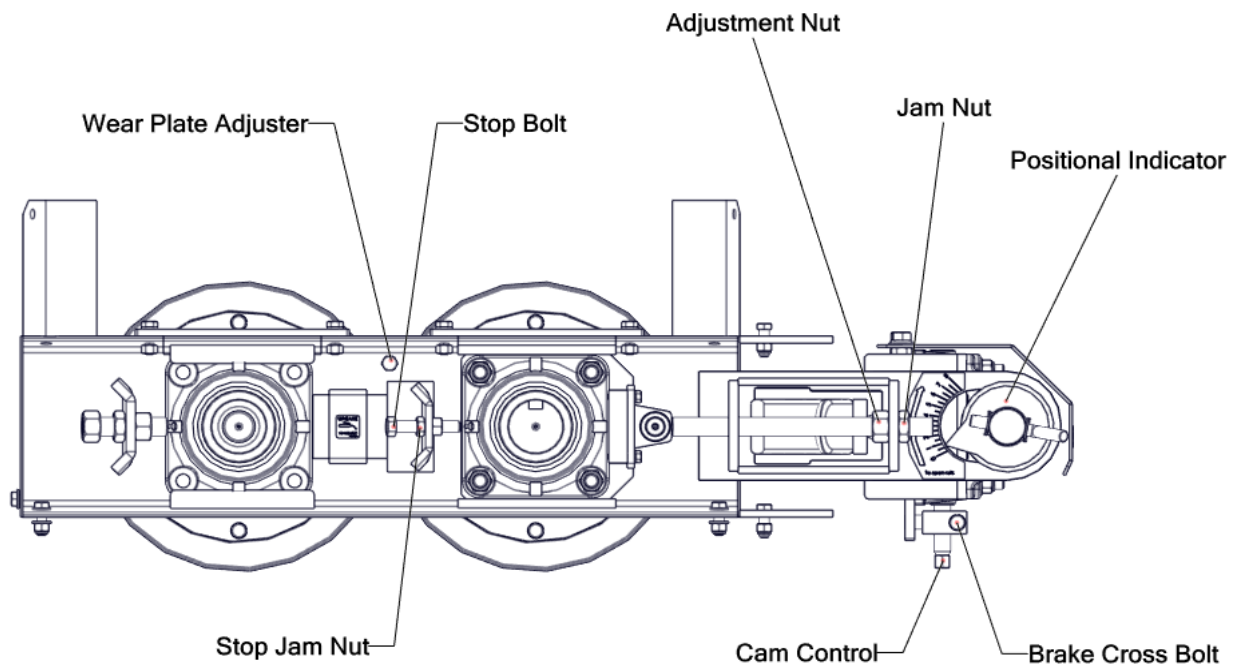

Figure 4.4

## 4 OPERATION

### 4.4.3 Feed Gate Control

Set the friction knob (Figure 4.5) so that it supports the weight of the feed gate and yet allows the gate to be opened and closed by hand. Note that the setting of the feed gate helps to spread the feeding of grain evenly across the face of the roll. The feed gate also serves to limit the overall flow of grain through the rolls.

### 4.4.4 Setting Wear Plates

Wear plates (Figure 4.6) are used to keep grain from escaping around the ends of the rolls. The positioning of the wear plates can be seen when the feed gate is fully open. A noise can be heard if the wear plates are contacting the rolls. To remedy this, loosen the jam nut and wear plate adjustment bolt (Figure 4.5) until the noise stops. Alternately, if the gap is excessive, turn the bolt into the plate until the plate touches the roll, then back off until the noise stops. Tighten the jam nuts when the desired setting is obtained. Be sure to maintain the position of ‘UHMW “V”’ (Figure 4.6) to cover the chamfer at the ends of the rolls. Replace as necessary.

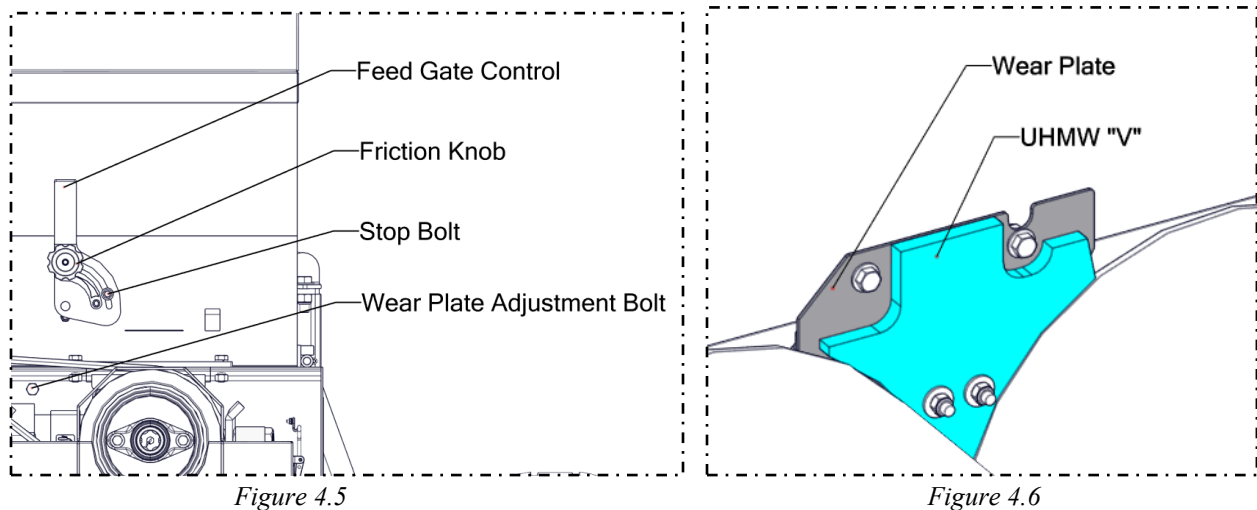

### 4.4.5 Cross Auger Drive Belt Tension

To increase belt tension, loosen the jam nut and turn the tensioning bolt until the required adjustment is reached. Reset the jam nut to lock the tensioning bolt in place.

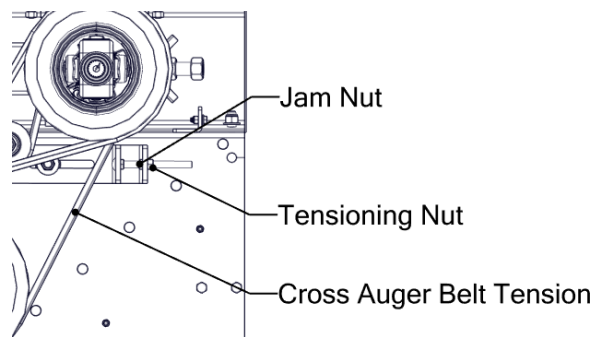
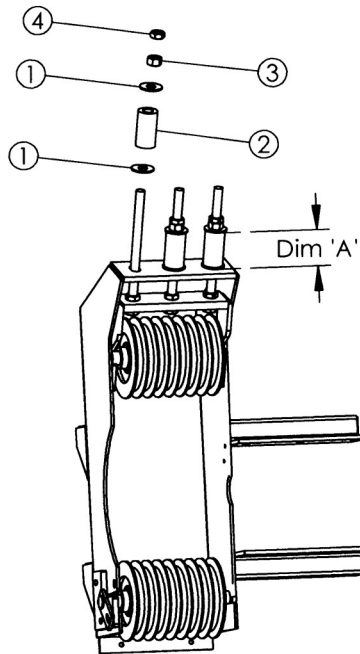

Figure 4.7

## 4 OPERATION

### 4.4.6 Roll Drive Belt Tension



- #1 3/4" Flat Washers
- #2 Compression Spring
- #3 3/4" NC Hex Nut
- #4 3/4" NC Jam Nut

For correct belt tension, adjust compression spring (Dim 'A') to:

8 Belt systems:  
2-7/8" - 3" long

4 Belt Systems:  
3" - 3 1/8" long

**NOTE :**

Whenever possible it is always best to minimize belt tension. This will extend belt and bearing life.

Figure 4.8

### 4.4.7 Spring Pressure

To increase spring pressure, loosen the jam nut and turn the spring push bolt inward a 1/2 turn at a time. Setting the pressure higher than necessary is hard on the bearings and the roll surfaces when hard particles like rocks go through the rolls. Always turn the bolts (if more than one) so that the load carried by each is the same. Maximum movement of the spring bolt is 3/4" from zero pressure. Bearing damage is likely to occur beyond this point.

*(Note: Figure shows top view of the mill; shield removed for illustration purposes only)*

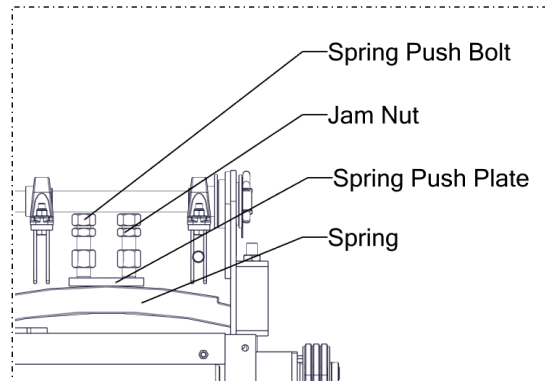

Figure 4.9

Leaf Spring Pressure (36" Roller Mill)		
Deflection (in)	lbs/in	
1.250	299	Factory Setting
1.500	353	
1.750	393	
2.000	471	Max for bearings

## 4 OPERATION

### 4.4.8 Grate Magnet

The grate magnet has slits on the edges (Figure 4.10). These can be removed with pliers to expand the top opening. This modification may aid in improving material flow when milling wet grain.

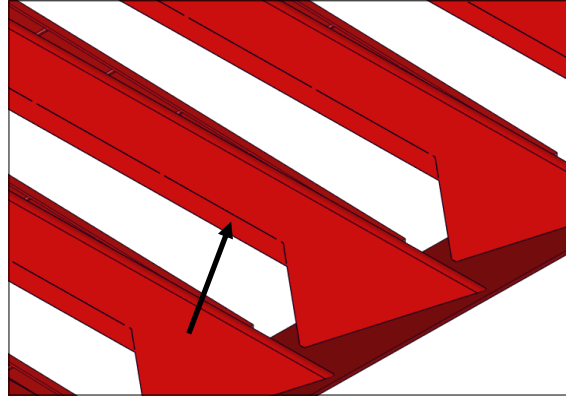

Figure 4.10

### 4.4.9 Auger Set Up

#### 1. Hitch Height

Level the mill with the tractor for best results.

#### 2. Set Up & Using the Transfer Auger

- A) Remove the safety pin and open the over-center latch on the transfer auger support that holds the transfer auger to the mill trailer (Figure 4.11).
- B) Open the top section of the auger support band (Figure 4.12).

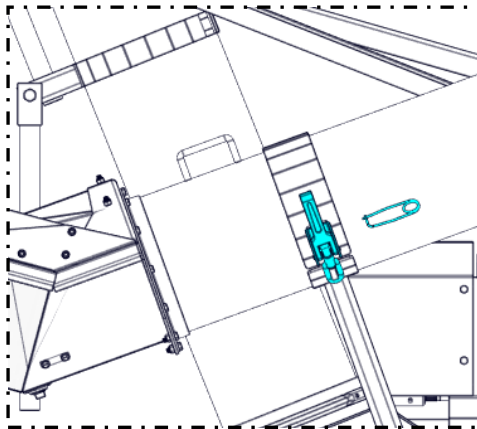

Figure 4.11

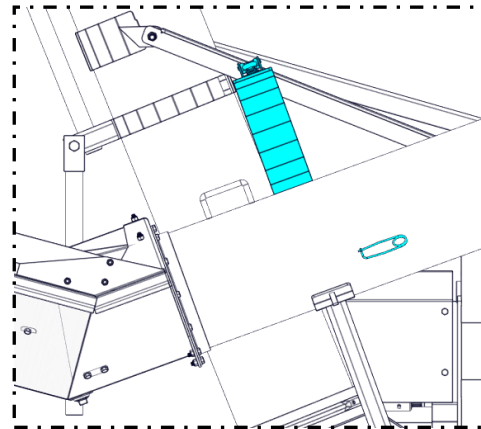

Figure 4.12

## 4 OPERATION

### 4.4.9 Auger Set Up (Cont'd)

- C) Once opened, you can use the hydraulics to lift the auger up until it is cleared to swing into position. The in feed auger can now be lowered into the needed position (Figure 4.13).
- D) The in feed auger is equipped with a free swing mechanism (Figure 4.114). This is used as a safety buffer to prevent damage to machine components by unexpected forces on the lift cylinder due to over-extension on the lift cylinder.

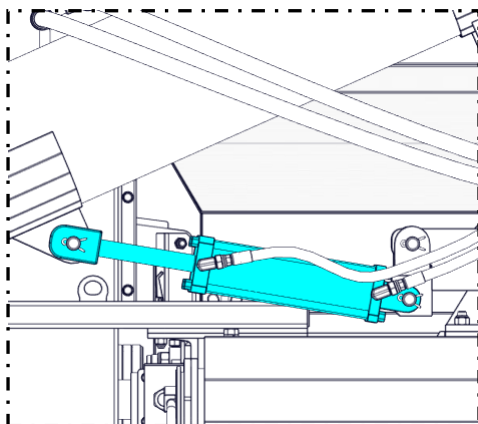

Figure 4.13

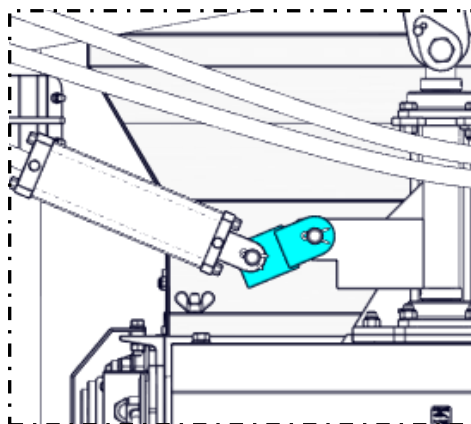

Figure 4.14

**Note:** When setting up the auger, use the hydraulics in a slow and steady manner, and watch for any components that could get caught and damaged while swinging into position. Do not over-extend the cylinder.

### 4.5 Operating the Roller Mill

1. Make sure to read and understand all of the safety items in Section 2.
2. Ensure that the feed gate is closed (Figure 4.5) before starting the mill. Even a few grains will keep the rolls from turning. Start the rolls turning at minimum RPM and slowly increase the RPM speed to 540.
3. Check the wear plate, roll gap, and feed gate friction nut settings.
4. Open the gate slowly and increase the flow, continuing to check grain quality as you do.  
**Note: Rolling quality is impacted by three variables: roll speed, spring pressure, and feed rate. If grain quality is good at low feed rates, but decreases quickly as feed rate increases, the spring pressure may be too low. To increase pressure, loosen the jam nuts and turn the spring push bolts (Figure 4.8) inward a 1/2 turn at a time. Keep the pressure even on both bolts (if applicable). In difficult cases, reducing the feed rate is one more way to control feed quality.**
5. Always ensure that the belt tension is adequate on the cross auger drive belt. Plugging of the mill can occur if the belts begin to slip significantly (see sections 4.4.5 & 4.4.6).
6. When finishing the rolling process, always clean the top hopper out completely and close the feed gate. Note that the feed gate stop bolt (Figure 4.5) can be used to set a consistent opening point. This maintains product consistency each time rolling is performed.
7. If not using the mill for some time, clean the grain out of the gearbox using the rear door access. Best practice is to store the mill under cover.



# 4 OPERATION

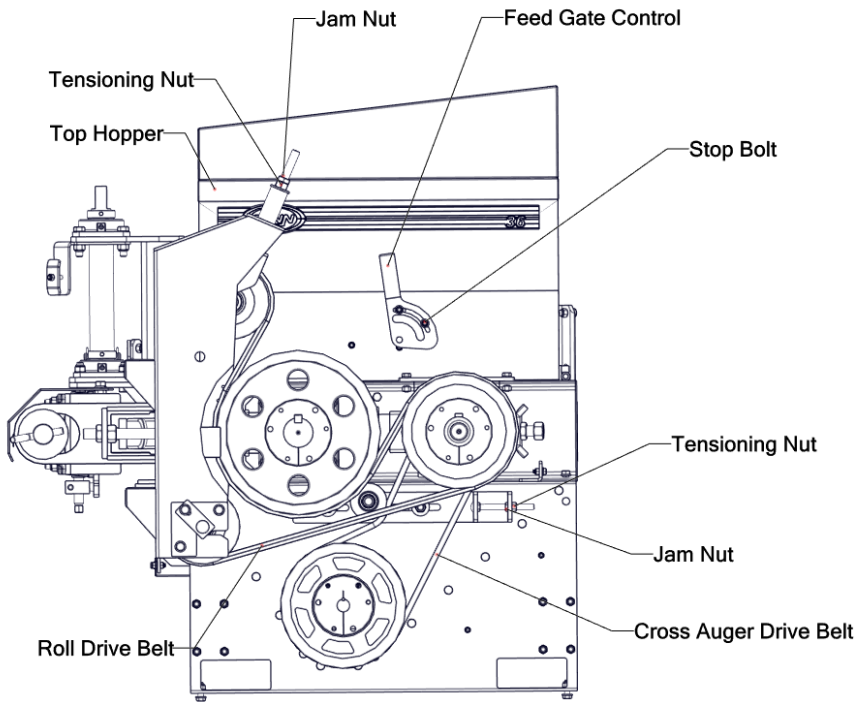

Figure 4.15

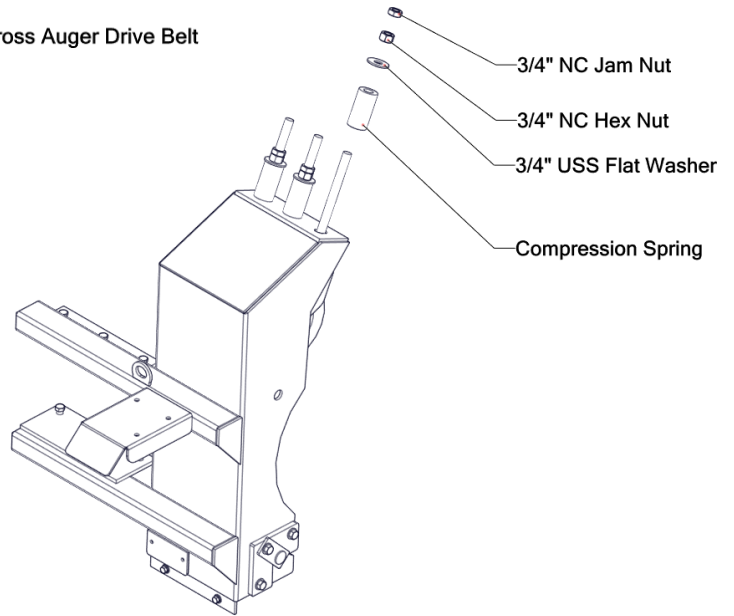

Figure 4.16

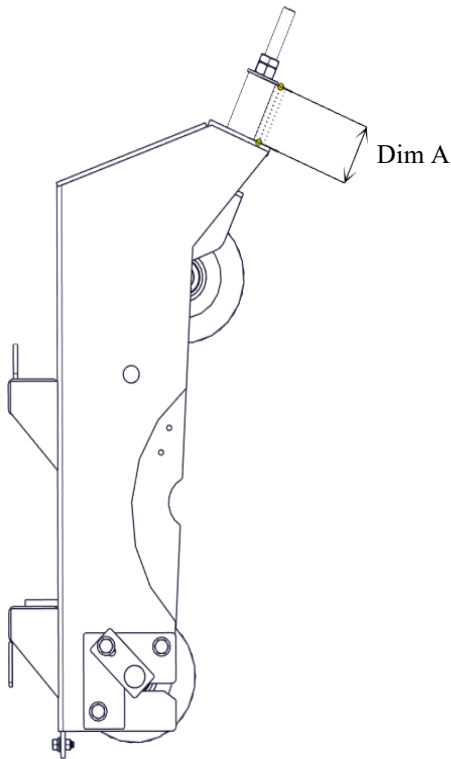

Figure 4.17

For correct belt tension, adjust compression spring (Dim 'A') to:

8 Belt systems:  
2-7/8" - 3" long

4 Belt Systems:  
3" - 3 1/8" long

**NOTE:**

Whenever possible it is always best to minimize belt tension. This will extend belt and bearing life.

## 4 OPERATION

---

### **4.6 Roller Mill Break-in**

It is recommended that the mill be run at moderate to full operational speed and at 1/2 to 2/3 capacity during the first hour of operation. This allows the frictional forces to diminish significantly within the auger tube, and allows the free flow of grain to approach acceptable levels in the system. Keep this in mind after the mill has been stored for extended periods of time as well.

It is also recommended that the following mechanical items be checked:

**1. At start up:**

- Check wear plate settings.
- Check roll gap settings.
- Check operation of the feed gate; set the friction nut.

**2. After operating for a 1/2 hour:**

- Re-torque all fasteners and hardware.
- Lubricate all grease fittings.
- Check operation of the feed gate; reset the friction nut as needed.
- Check the roll gap setting. Due to the use of mechanical means to hold the roll in place, “settling” can occur within the system due to spring impact and other factors.
- Check the setting of the gap between the rolls, not only for a change in gap setting, but also for gap consistency from one end of the roll to the other.

*A half hour of running will take care of any inconsistencies in the roll surface, and allow an accurate setting of the roll gap. See 4.4.1 for setting of the roll gap.*

**3. After 5 hours and 10 hours of operation:**

- Re-torque all wheel bolts, fasteners and hardware.
- Lubricate all grease fittings - do not over-grease.
- Proceed to the normal servicing and maintenance schedule as defined in the Maintenance Section (section 5).

## 4 OPERATION

---

### **4.7 Reduction Gearbox**

The reduction drive option included with this mill enhances the variety of applications beyond those of the standard mill to include bagging, blowing, and any other secondary application requiring the same or a reduced input power. The reduction box can be used to run the secondary machine at speeds of 540 or 1000 RPM.



*Figure 4.18*

## 5 SERVICE AND MAINTENANCE

### 5.1 Servicing Record

See the Lubrication and Maintenance sections for details of service. Copy this page to continue record.

ACTION CODE: CL.....CLEAN                      T.....TIGHTEN  
                   L.....LUBRICATE                CH.....CHECK

<div style="display: flex; justify-content: space-between;"> <span>MAINTENANCE</span> <span>Hours Served By</span> </div>																				
<b>8 Hours of Driveline Use</b>																				
L    U-Joint - PTO																				
L    U-Joint , Bearings- Transfer Auger																				
L    Main Bearings - Rolls																				
L    Cross Auger Bearing																				
L    Reduction Box Bearings																				
L    Discharge Auger Bearing																				
<b>50 Hours of Use</b>																				
CH   Rolls Position - Square																				
L    Gear Box - Replace Oil - 200 hrs. - Check Level - 50 hrs.																				
L    Cam Bearings																				
CL   Vent																				
L    Chain Coupling - Transfer Auger																				
<b>Annually</b>																				
T    All Fasteners																				
L    Wheel Hubs																				
L    Lift & Swing Pole Bearings																				
CL   Machine																				
CH   Wear Plates																				
CH   Oilite Bushing - Transfer Auger																				
L    Jack																				

## 5 SERVICE AND MAINTENANCE

### 5.2 Servicing Intervals

#### **Grease**

Use an S.A.E. multi-purpose high temperature grease with extreme pressure (EP) performance. An S.A.E. multi-purpose lithium base grease is also acceptable.

Use the Maintenance Checklist provided to keep a record of all scheduled maintenance.

1. Only use a hand-held grease gun for all greasing.
2. Wipe grease fittings with a clean cloth before greasing to avoid injecting dirt and grit.
3. Replace and repair broken fittings immediately.
4. If a fitting will not take grease, remove and clean thoroughly. Clean the lubricant passage-way also. Replace fittings as necessary.

#### **Oil**

Use 80W90 oil for discharge auger gearbox.

Use the Maintenance Checklist provided to keep a record of all scheduled maintenance.

PTO, front and rear yoke: grease zerk (every 8 hours)



PTO, mid: grease zerk, extend PTO and rotate shield to find zerk (every 8 hours)



Main bearings: grease zerk front and rear (every 8 hours)



## 5 SERVICE AND MAINTENANCE

### 5.2 Servicing Intervals (Cont'd)

Cam adjuster bearings (grease lightly every 50 hours)

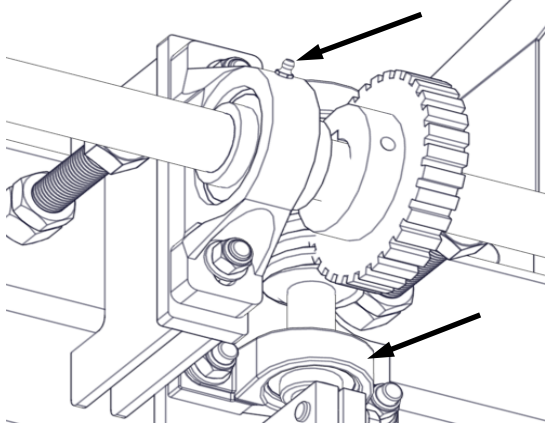

Wheel hub: grease zerk (once per season)

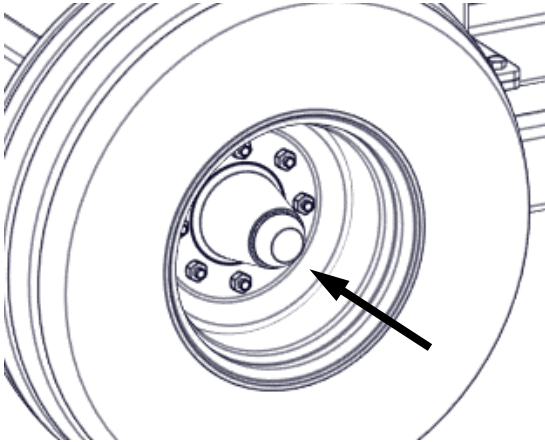

Transfer auger bearing: grease zerk (every 10 hours)

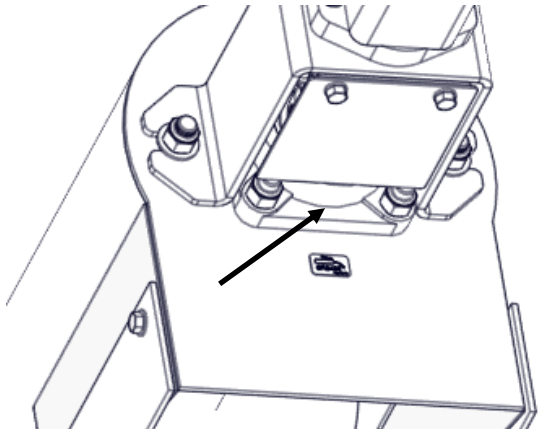

Jack: grease zerk (once per season)



Feed Auger Support Bearings (every 8 hours)

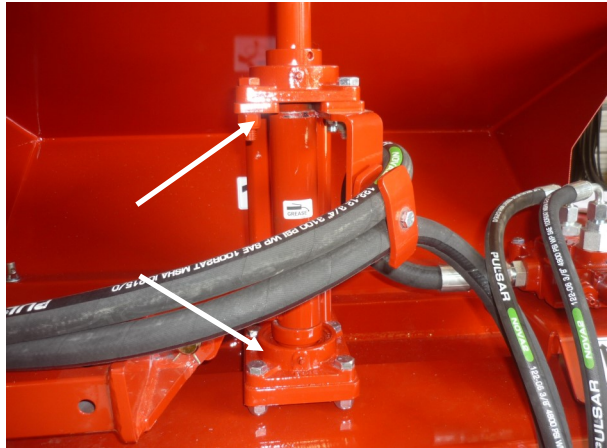

Transfer auger: grease zerk (every 8 hours)

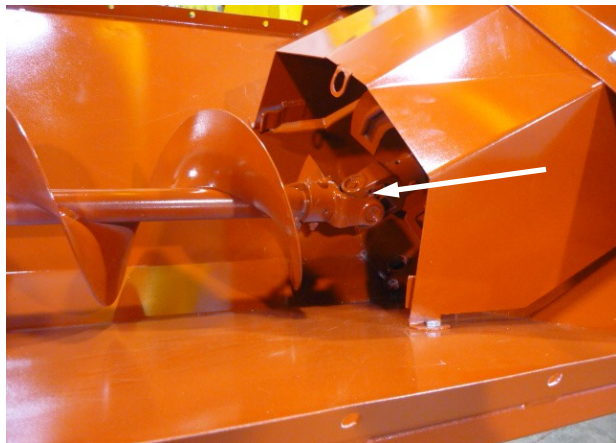

**IMPORTANT:** Retorque wheels after 100Kms of towing or 8 hours of operation. Refer section 10 for torque specification.

## 5 SERVICE AND MAINTENANCE

### 5.2 Servicing Intervals (Cont'd)

Transfer auger bearing: grease zerk (every 10 hours)

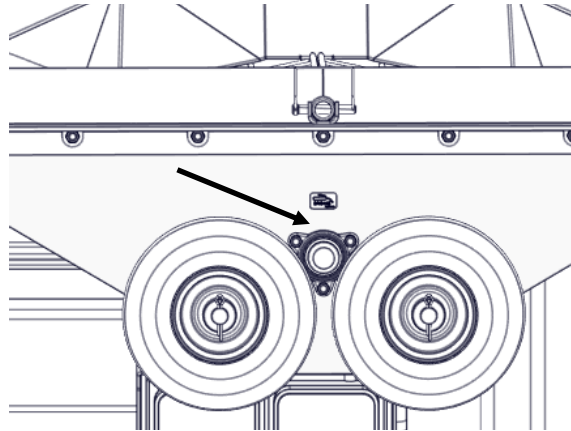

For discharge gearbox oil level check -

1. Take out the gearbox.
2. The oil plug is located on the side of the gearbox.
3. Lay the gearbox on its side with the plug removed to drain the oil.
4. Stand the gearbox up in the orientation it will sit in when installed. Fill the gearbox with oil until it is level with the bottom of the plug hole. Replace the plug and reinstall the gearbox.
5. Torque the bolts to spec when reattaching to the gearbox housing (30 ft. lbs.).

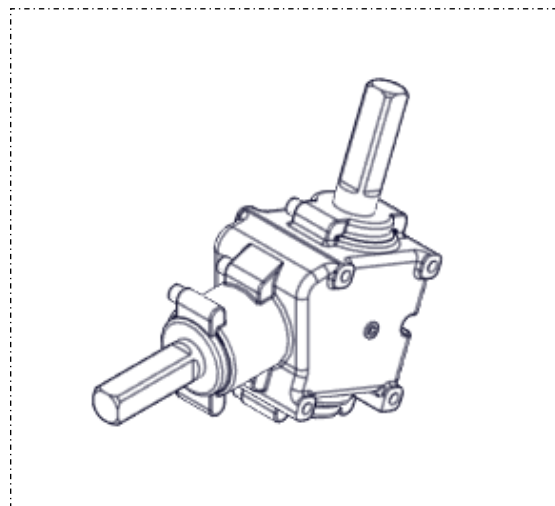

## 5 SERVICE AND MAINTENANCE

### 5.3 Removal Of Rolls For Servicing

1. With the power disconnected, loosen the jam nuts on each of the spring push bolts and relieve all pressure from the spring (see section 4.4.6).
2. Relieve the tension on the roll drive belts and remove.
3. Loosen the jam nuts on the tensional bolt. Loosen and remove the belts.  
*Note: To get these belts out you must remove both idler rollers. To do this, completely remove the tensioner nuts to allow the tensioner bracket to be disengaged from the upper idler roller. Release the fasteners holding the lower idler roller and remove, then remove the upper idler roller.*
4. Loosen the wing nuts holding the top hopper down and lift the topper up, over center, gently setting it on the rests.
5. Loosen and remove the bearing hold-down straps.
6. Remove the bolts that tie the cam base to the bearing slide.
7. After loosening the brake, turn the cam controller to create some space between the bearing slide and the cam base.
8. Remove 1 roll at a time. *Note: Rolls are heavy, take appropriate precautions.*

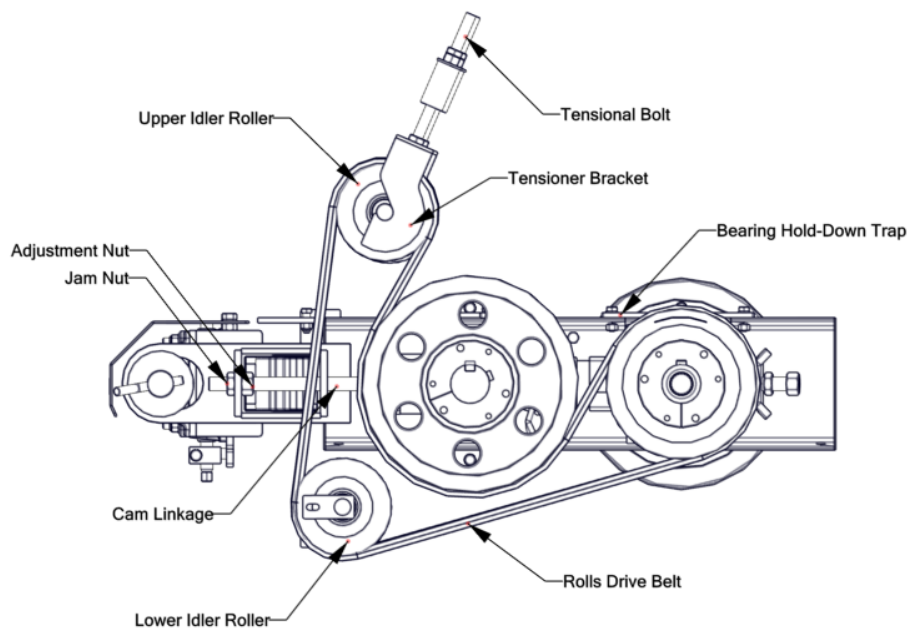

### TO SET DRIVE ROLLS AFTER RE-INSTALLATION

- Refer to Section 4.4.1.

### OPERATION

- Prior to start-up, ensure that the roll gap is preset to the desired setting by putting a 1 bushel sample through the rolls at rated speed. This will indicate what the sample will look like during normal operation. Adjust the gap and spring pressure as necessary, based on the rolled sample.
- See section 4.4.2 for roll setting procedures. When using the cam system, loosen the brake cross bolt at the base of the vertical shaft found at the center of the system, then proceed to turn the cam adjuster at the bottom of the vertical shaft to adjust the roller setting. Always tighten the brake when finished. Adjustments can be made under load without issue.



## 6 PDI SETUP

---

Your Renn Mill may come with some parts pre-assembled.

Note:

- Practice proper safety procedures when lifting heavy objects.
- Parts illustrated on these pages are to demonstrate what parts may need to be assembled.
- All hoses should be on the hose hanger when not in use.

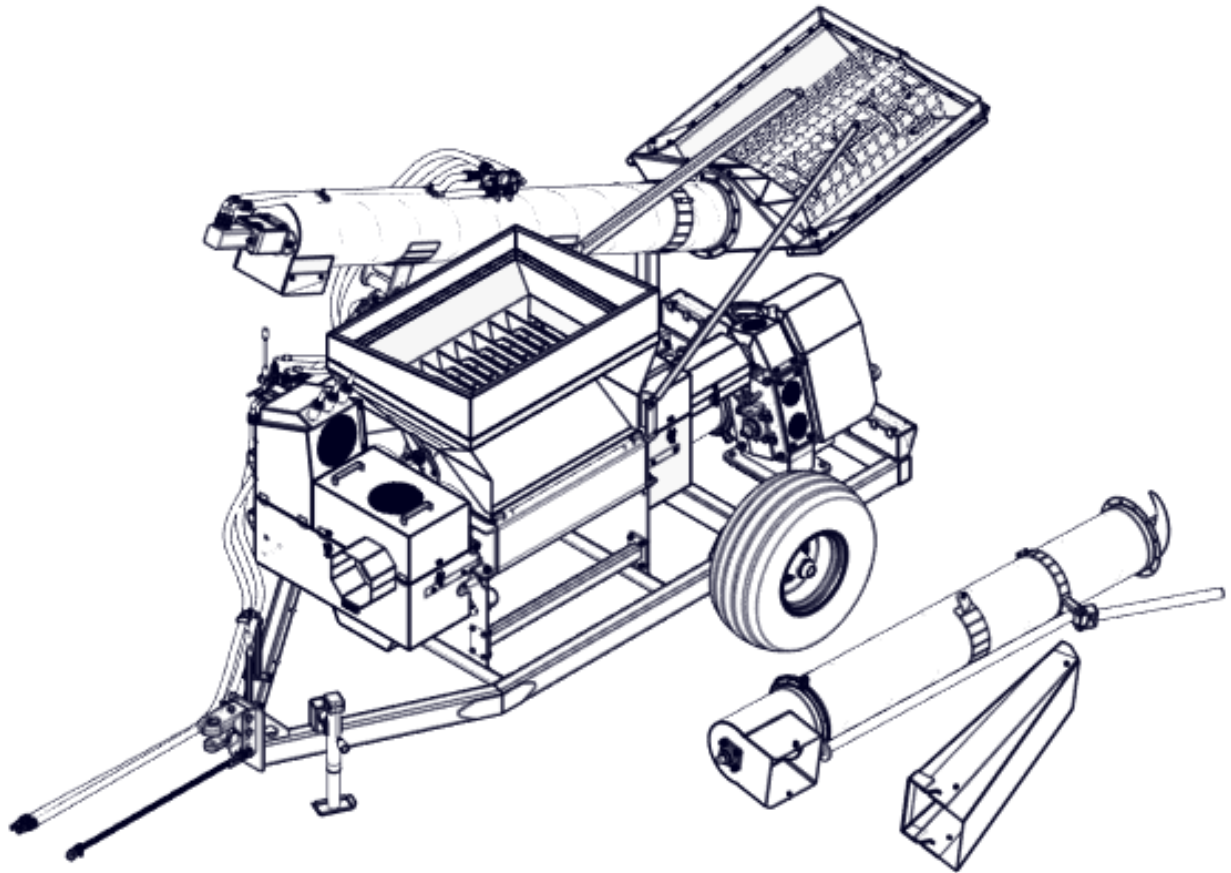

***IMPORTANT: Use proper safety procedures when lifting heavy objects.***

## 6 PDI SETUP

1. Remove existing washers/nylock nuts on the top of the discharge auger and use it to fasten the discharge chute and spout cap together to the auger.

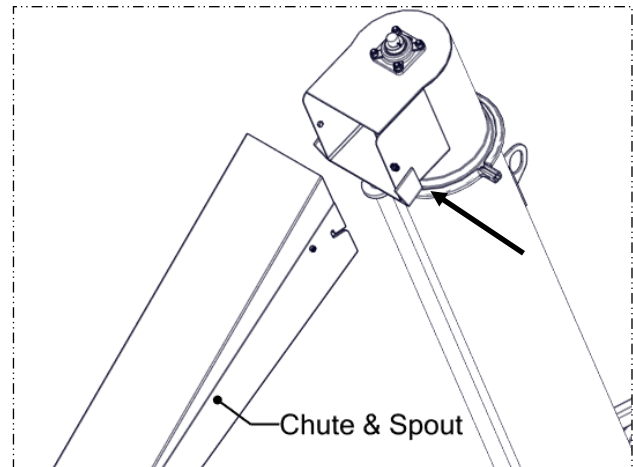

2. Remove the clamp band from the top of the gearbox.
3. Attach the discharge auger to the gear box using the clamp and existing carriage bolts/nuts, with the discharge spout facing towards the back of the machine.

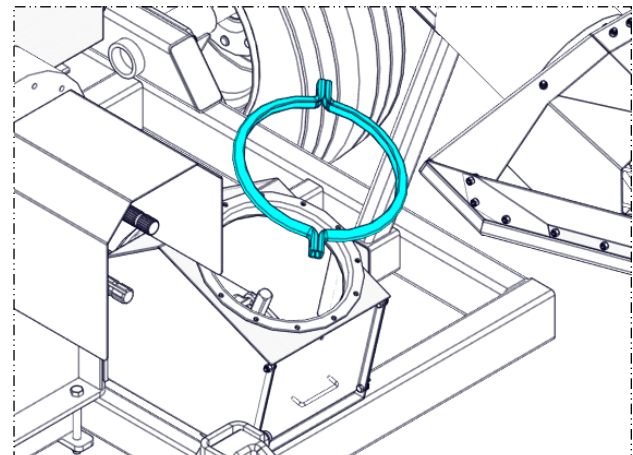

4. Using the door in the gearbox, ensure that the leading edge of the discharge auger flighting is between the 9 and 11 o'clock position, when the kicker plate is horizontal.

***NOTE: Improperly aligned flighting may cause impact, resulting in damage to the flighting and poor grain movement.***

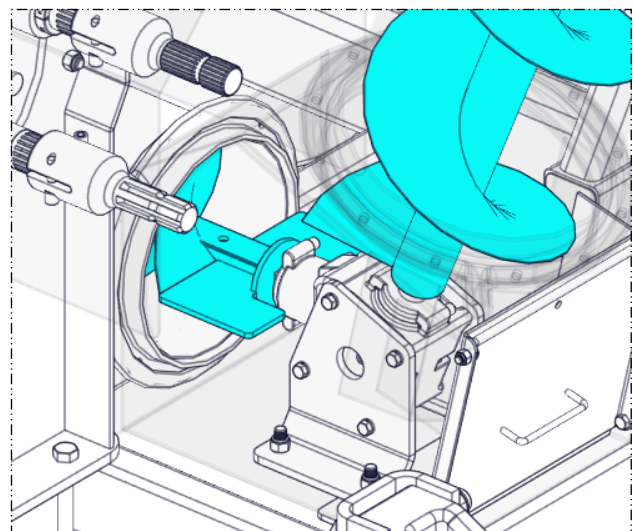

***IMPORTANT: Use proper safety procedures when lifting heavy objects.***

## 6 PDI SETUP

5. To secure the discharge auger in place, attach the support arms on both sides, using the existing hardware.

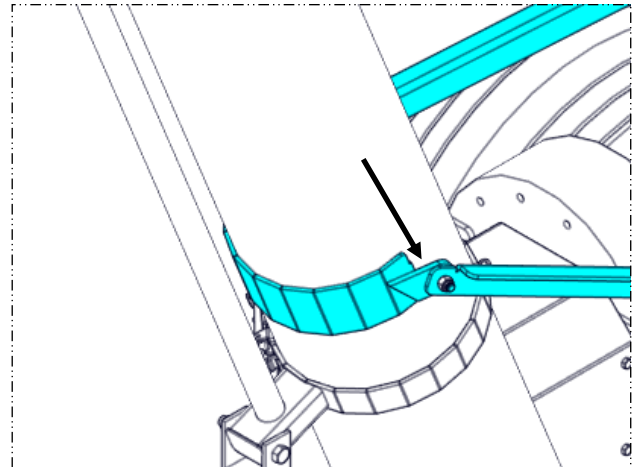

### How to use the hose hanger:

- A) Open the quick pin that is holding the lock plate and the front panel of the hose hanger.
- B) Rotate the lock plate clockwise. If the lock plate is too tight, loosen the bolt at the bottom of the lock plate.

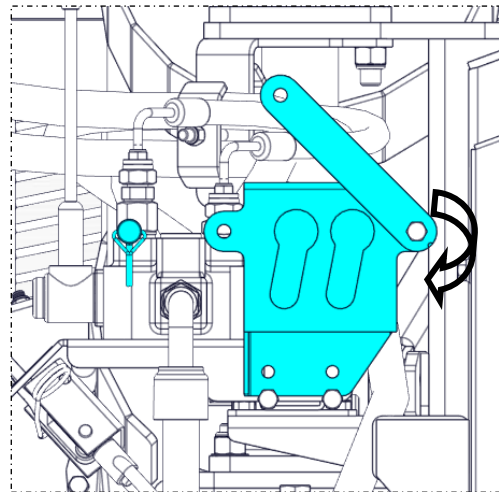
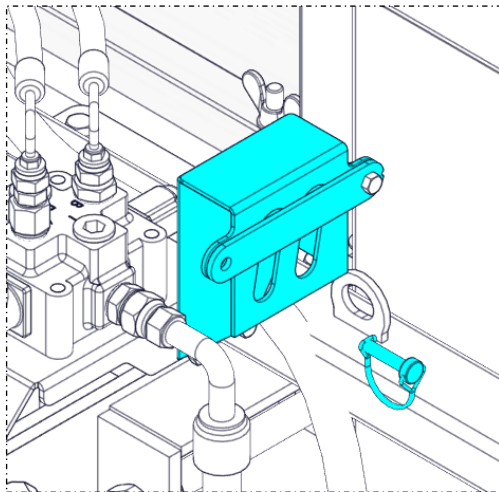

- C) Hang the hoses on the hanger.
- D) Place the lock plate and the pin back on.

**Note:** All hoses should be on the hose hanger when not in use.

## 7 TRANSPORTATION

---



1. Check with local authorities regarding mill transportation on public roads. Obey all applicable laws and regulations.
2. Always travel at a safe speed. Use caution when going around corners or meeting traffic.
3. Make sure an SMV (Slow Moving Vehicle) emblem and all the lights and reflectors that are required by local highway and transportation authorities are in place, are clean and can be seen clearly by all overtaking and oncoming traffic.
4. If possible use a light kit when transporting. Be sure all lights attached to the rear of the mill are working to safeguard against rear end collisions. Daybreak and dusk are particularly dangerous and pilot vehicles are recommended.
5. Be sure that the mill is hitched positively to the towing vehicle and a retainer is used through the drawbar pin. Always use a safety chain between the machine and the towing unit.
6. Keep to the side and yield the right-of-way to allow faster traffic to pass. Drive on the shoulder of the road if safe to do so and permitted by law.
7. Do not exceed a 25mph (40kph) travelling speed. Reduce speed on rough roads and surfaces. Reduce speed when going around tight bends and corners in the road. Be especially careful when traveling on roads with a significant center crown, or when moving to the shoulder of the road with one wheel.
8. Always use the hazard warning flashers on the tractor when transporting unless prohibited by law.
9. When transporting a mill with a conveyor or auger discharge, be aware of overhead power lines at all times.
10. Have a minimum distance of 18 inches from the machine hitch to the tractor PTO, otherwise damage may occur to the tractor or mill.

**Do not transport the mill without all of the transport pins and clamps installed and fastened.**

## 8 STORAGE

---

### **8.1 Placing in Storage**

At the end of the operating season, the machine should be thoroughly inspected and prepared for storage. Repair or replace any worn or damaged components to prevent any unnecessary down time at the beginning of the next season. Follow this procedure:

1. Thoroughly clean the machine to remove all dirt, mud, debris or residue.
2. Lubricate all grease points. Make sure that all grease cavities have been filled with grease to remove any water left over from clean up.
3. Inspect all hydraulic hoses, couplers and fittings. Tighten any loose fittings. Replace any hose that is badly cut, nicked, abraded or is separating from the crimped end of a fitting.
4. Touch up all paint nicks and scratches to prevent rusting.
5. Move the machine to the storage location.
6. Select an area that is dry, level and free of debris.
7. Chock the tires, front and rear, to prevent the machine from rolling.
8. Place planks under the jack for added support if required.
9. Unhook the machine from the tractor.

### **8.2 Removing from Storage & Pre-Season Preparation**

When removing from storage and preparing to use, follow this procedure:

1. Clear the area of bystanders, especially small children, and remove foreign objects from the machine and the working area.
2. Remove any storage covers used to protect the machine.
3. Attach the auxiliary mill to the tractor.
4. **INSPECTION:**
  - a) Check that all hydraulic lines are seated and completely coupled.
  - b) Check that all bearing locking collars on the shafts are tight and in good condition.
  - c) Check that all set screws on the bearing collars are tight.
  - d) Check that all bearing mounting bolts are tight.
  - e) Check that all tires are inflated per the recommended pressures.
  - f) Re-torque all wheel bolts.
5. Lubricate all grease fittings.
6. Replace any defective parts.
7. Go through the **Pre-Operational Checklist** (Section 4.3) before using.

## 9 TROUBLESHOOTING GUIDE

PROBLEM	CAUSE	REMEDY
Whole grain in sample	Wear plate not adjusted.	With power disconnected & rolls not rotating, use a 3/4" wrench to loosen the jam nut on the wear plate adjuster. Adjust the wear plates in so that there is minimal clearance between the end of the rolls & the wear plates and tighten the jam nuts. This will prevent any whole grain from passing around the end of the rolls. Maintain the position of the poly 'V' section to cover the chamfer at the ends of the rolls. Replace as necessary.
Wear plates and poly 'V' adjusted, roll gap at desired setting, <u>whole grain in sample</u> when gate is opened for increased flow	Rolls are opening up when negative pressure is applied from grain going between rolls.	Decrease flow of grain by closing inlet gate or Increase spring pressure by turning the spring adjusting bolts clockwise. <i>NOTE : When increasing spring pressure add pressure by turning the adjusting bolts in increments of 1/2 turn inward at a time. i.e. (1) adjust in 1/2 turn increments (2) check sample, if not as desired repeat steps 1 &amp; 2.</i>
Wear plates checked, spring pressure is sufficient, cam positional indicator adjusted to the #1 position or less, gap still too wide for desired rolling	Roll has worn or is out of adjustment.	See Sections 4.4.1 & 4.4.2 for resetting the roll gap.

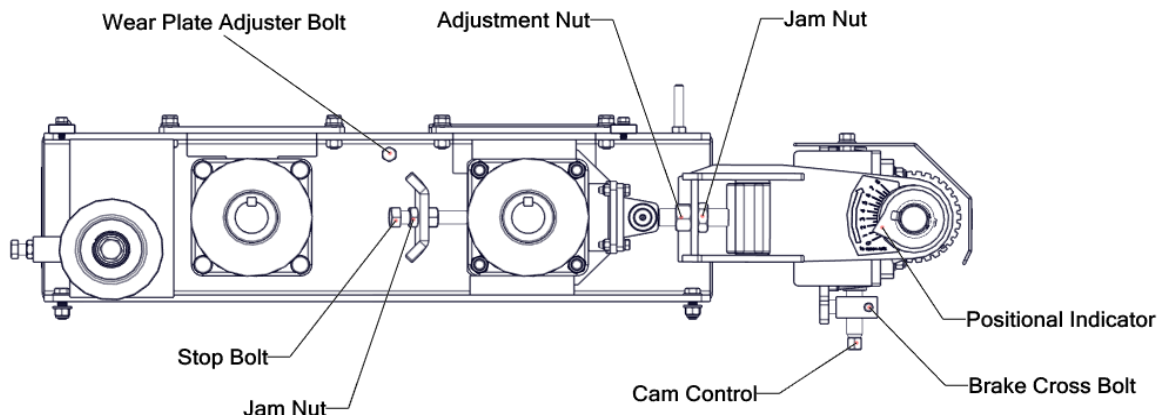

## 9 TROUBLESHOOTING GUIDE

PROBLEM	CAUSE	REMEDY
Wear plates and poly 'V', roll gap & spring pressure set properly, still <u><i>whole grain in sample</i></u>	Grain smaller than the space between the grooves.	Need finer groove pattern.  Rolls need re-grooving or are no longer true (badly worn).
Grain is rolled too fine	Roll gap is too narrow.	Using the cam control, release the cam brake and move the indicator toward the #2 position (or next largest number - a 1/2 turn at a time, checking a sample at each 1/2 turn).
Grain is rolled too fine, gap is set to desired setting  Coarse grains (corn, peas, lupins)  Small grains (wheat , oats, barley, milo)	Roll pattern is too fine (i.e. more grooves per inch than necessary).  Rolls are turning faster than through-put.	Change roll to a coarser groove pattern.  Slow the R.P.M. down. The closer the roll speed is to the grain through-put the more consistent the rolled product will be.

# 10 SPECIFICATIONS

---

## **10.1 General Specifications**

Weight..... 7560 lbs  
Minimum Tractor Horsepower..... 140 hp - PTO  
Auger Discharge Size..... 12" x 8'  
Transfer Auger Size ..... 12" x 10'

## **10.2 Tire Specifications**

Tire/Rim..... 12.5L - 15FI-I TIRE/RIM 8 BOLT RIM  
Tire Pressure ..... Check Tire for Info

## **10.3 Bolt Torque Specifications**





Wheel Bolts/Nuts ..... 90-120 ft.lbs.  
PTO Shear Bolts *7/16" NC x 1" Gr.5 Shear Bolt*..... 50 ft.lbs.  
..... *All Other Bolts—Refer to Bolt Torque Chart On Following Page*

**IMPORTANT:** Retorque wheels after 100Kms of towing or 8 hours of operation. Refer section 10 for torque specification.



# 10 SPECIFICATIONS

## BOLT TORQUE CHART

SIZE							
	SAE GRADE 2		SAE GRADE 5		SAE GRADE 8		L9
	ASSEMBLY TORQUE DRY	LUBRICATED	ASSEMBLY TORQUE DRY	LUBRICATED	ASSEMBLY TORQUE DRY	LUBRICATED	ASSEMBLY TORQUE LUBRICATED
1/4-20	66*	49*	8	75*	12	9	11
1/4-28	76*	56*	10	86*	14	10	13
5/16-18	11	8	17	13	20	18	21
5/16-24	12	9	19	14	25	20	23
3/8-16	20	15	30	23	45	30	33
3/8-24	23	17	35	25	50	35	38
7/16-14	30	24	50	35	70	55	60
7/16-20	35	25	55	40	80	60	65
1/2-13	50	35	75	55	110	80	95
1/2-20	55	40	90	65	120	90	105
9/16-12	65	50	110	80	150	110	140
9/16-18	75	55	120	90	170	130	150
5/8-11	90	70	150	110	220	170	185
5/8-18	100	80	180	130	240	180	205
3/4-10	160	120	260	200	380	280	290
3/4-16	180	140	300	220	420	320	355
7/8-9	190	140	400	300	600	460	505
7/8-14	210	155	440	320	660	500	585
1-8	220	160	580	440	900	680	775
1-14	240	170	640	480	1000	740	900
1 1/8-7	300	220	800	600	1280	960	1150
1 1/8-12	340	260	880	660	1440	1080	1325
1 1/4-7	420	320	1120	840	1820	1360	1600
1 1/4-12	460	360	1240	920	2000	1500	1750
1 3/8-6	560	420	1460	1100	2380	1780	—
1 3/8-12	640	460	1680	1260	2720	2040	—
1 1/2-6	740	560	1940	1460	3160	2360	3250
1 1/2-12	840	620	2200	1640	3560	2660	3650

**ITEMS WITH \* = INCH POUNDS  
ALL OTHERS = FOOT POUNDS**

**"LUBRICATED"  
INCLUDES LUBRICANTS, LUBRIZING, PLATING, AND HARDENED WASHERS**

# 10 SPECIFICATIONS

## 10.4 Overall Dimensions

### 10.4.1 Working Mode

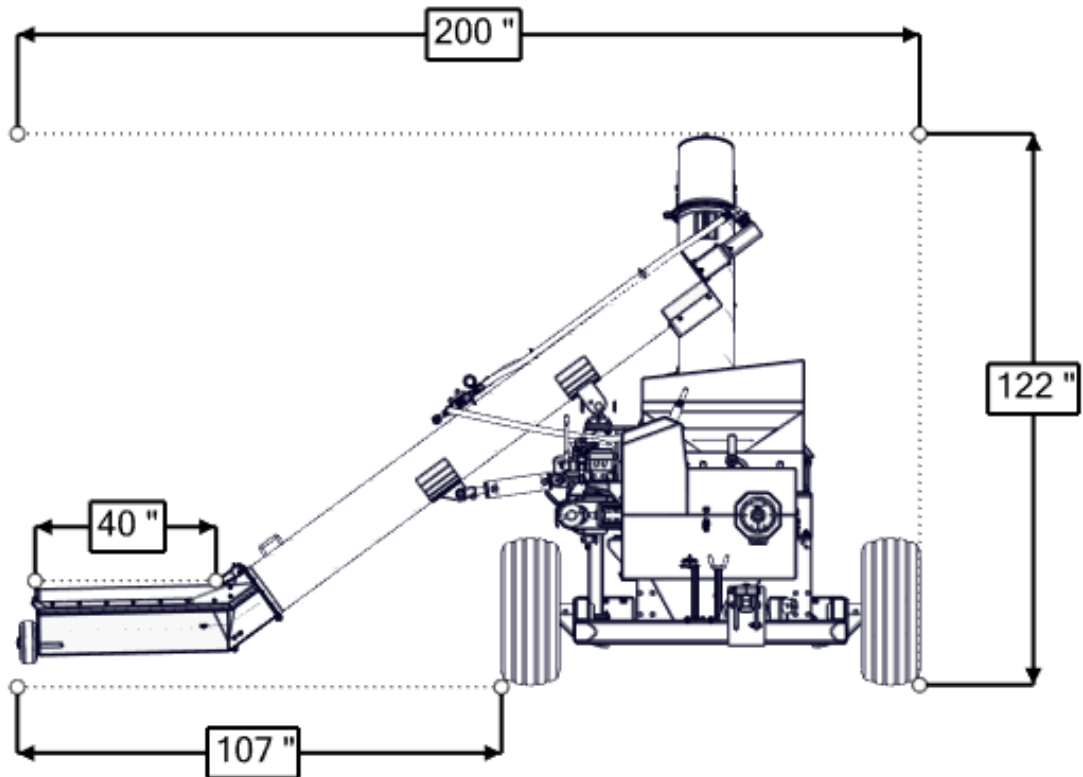
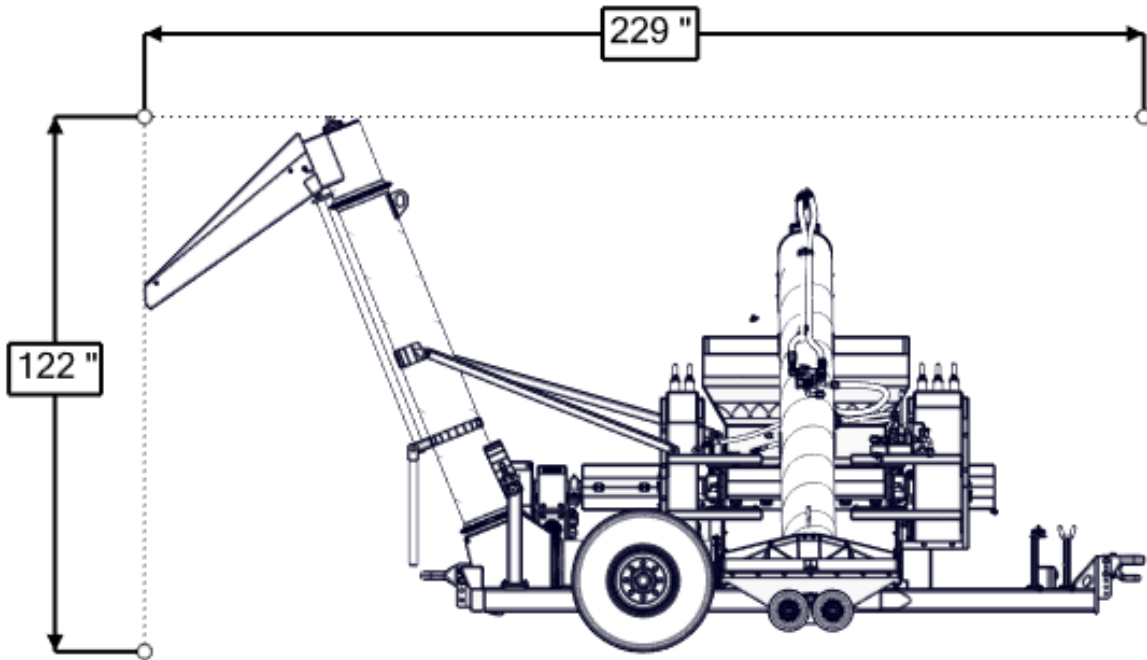

# 10 SPECIFICATIONS

## 10.4 Overall Dimensions

### 10.4.2 Transport Mode

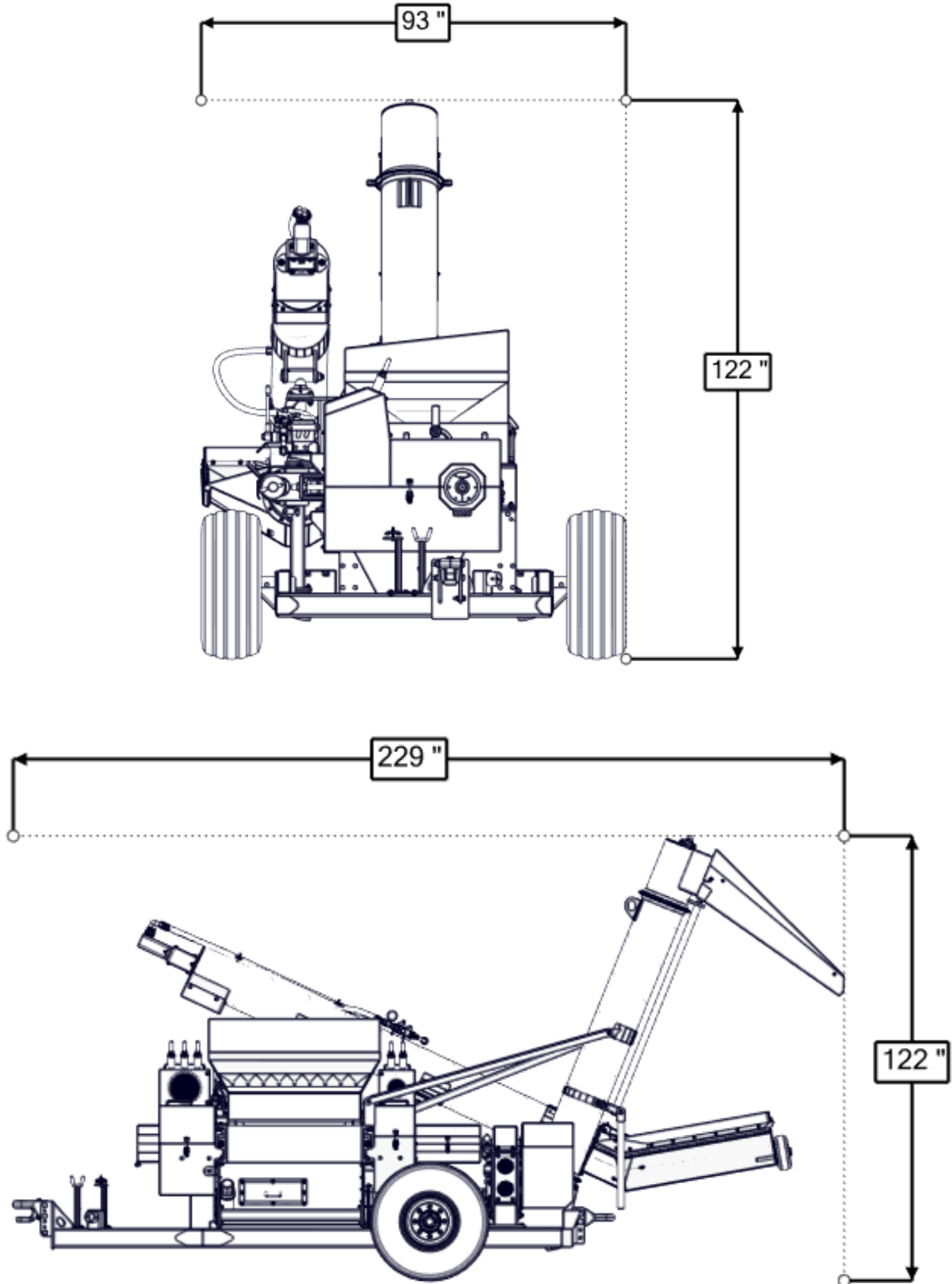

## 11 PARTS

### 11.1 Top Hopper

REF #	PART #	DESCRIPTION	QTY
1	673600-0051.00	Top Hopper Extension - 36"	1
2	613600-0083.00	Grate Magnet - 36"	1
3	613600-0615.00	Top Hopper Weldm't - 2020	1
4	159300-0730	Hex Bolt - 5/16" NC x 3/4" Gr.5 PL	14
5	168000-0040	Flat Washer - 5/16" USS PL	32
6	167200-0648	Nyloc Nut - 5/16" NC Gr.5 PL	18
7	159300-0944	Hex Bolt - 3/8" NC x 3/4" Gr.5 PL	8
8	168000-0540	Flat Washer - 3/8" SAE	4
9	147100-0288	UHMW Wear Plate Insert - 10"	2
10	411200-0832.01	Wear Plate - 10"	2
11	167200-0652	Nyloc Nut - 3/8" NC Gr.5 PL	8
12	163000-0302	Carriage Bolt - 5/16" x 1-1/4" Gr.5 PL	4
13	413600-0592.00	Grain Containment Belt - 36"	2
14	613600-0012.00	Hinge Pin - 36"	1
15	170000-0180	Cotter Pin - 3/16" x 1"	1

## 11 PARTS

### 11.1 Top Hopper

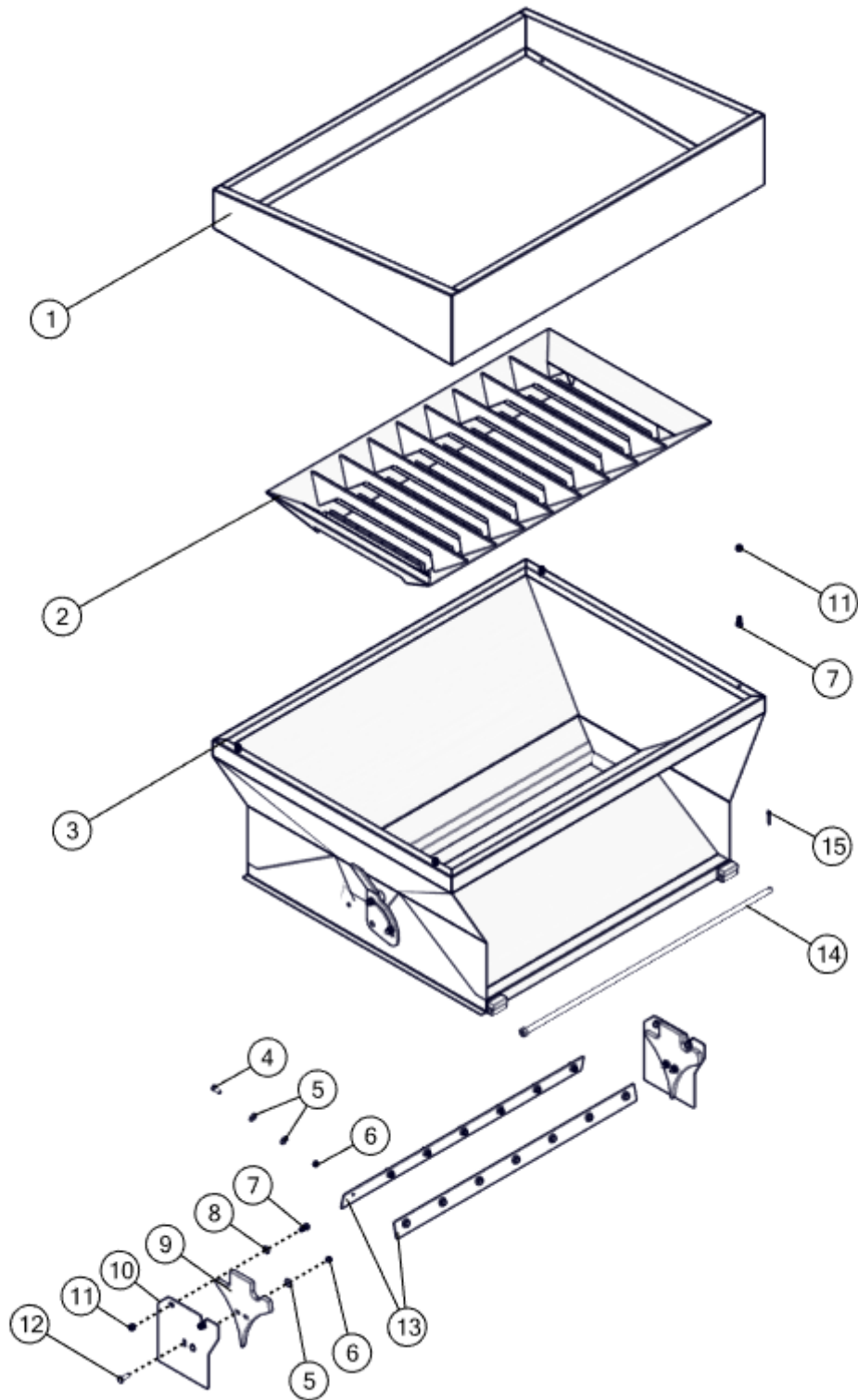

## 11 PARTS

### 11.1.1 Top Hopper (Knob)

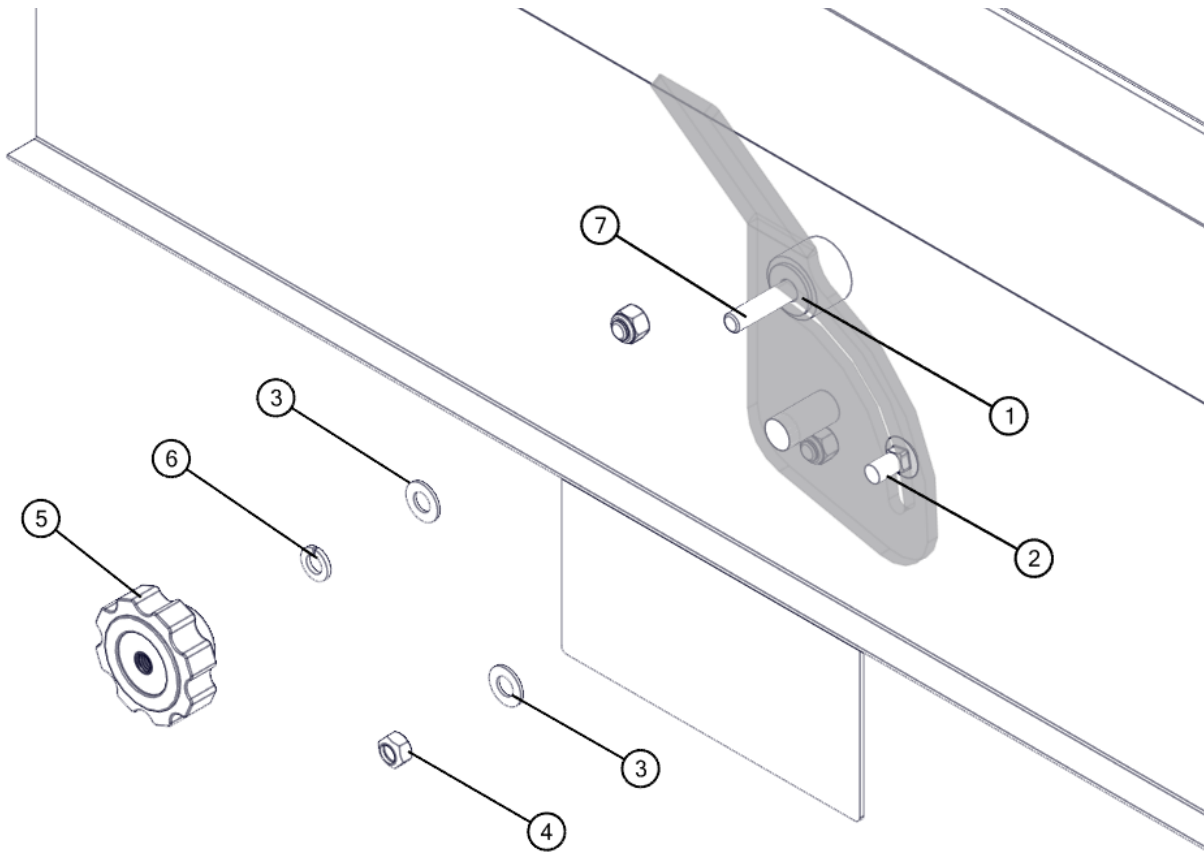

REF #	PART #	DESCRIPTION	QTY
1	168000-0049	Flat Washer - 3/8" USS PL	1
2	163000-0506	Carriage Bolt 3/8" NC x 3/4" Gr.5 PL	1
3	168000-0540	Flat Washer - 3/8" SAE	2
4	167200-0412	Lock Nut - 3/8" NC	1
5	140000-0224	Lock Knob	1
6	168600-0071	Lock Washer - 3/8" PL	1
7	159400-0004	Hex Bolt - 3/8" NC x 2-1/2" Gr.5 PL	1

**THIS PAGE INTENTIONALLY LEFT  
BLANK**

## 11 PARTS

### 11.2 Idler Attachment

REF #	PART #	DESCRIPTION	QTY
1	615000-0704.01	Idler Tensioning Frame	1
2	615000-0904.01	Front Idler Housing	1
3	159300-0961	Hex Bolt - 3/8" NC x 1" Gr.5 PL	5
4	161500-0498	Quick Pin, 3/8" x 1-5/8"	1
5	414000-0991.00	Lock Plate - Hose Hanger (1 set)	1
6	614000-0320.00	Hose Hanger (1 set)	1
7	167200-0652	Nyloc Nut - 3/8" NC Gr.5 PL	5
8	159400-0401	Hex Bolt - 1/2" NC x 1-1/2" Gr.5 PL	12
9	167200-0688	Nyloc Nut - 1/2" NC Gr.5 PL	12
10	670000-0199.00	Mounting Bracket - Bolt-on - Direction Control Valve	1
11	167000-0835	Hex Nut - 3/4" NC Gr.5 PL	5
12	303100-0204	Compression Spring - 1.75" OD x 3.41" Long	5
13	167000-0675	Jam Nut - 3/4" NC Gr.5 PL	10
14	168000-0090	Flat Washer - 3/4" USS PL	5
15	415000-0726.00	Tensioner Rod - 3/4" NC	5
16	615000-0803.00	Tensioning Frame - 4 Belt	1
17	615000-0817.01	Idler Housing Weldment - 4 Belt	1



# 11 PARTS

## 11.2 Idler Attachment

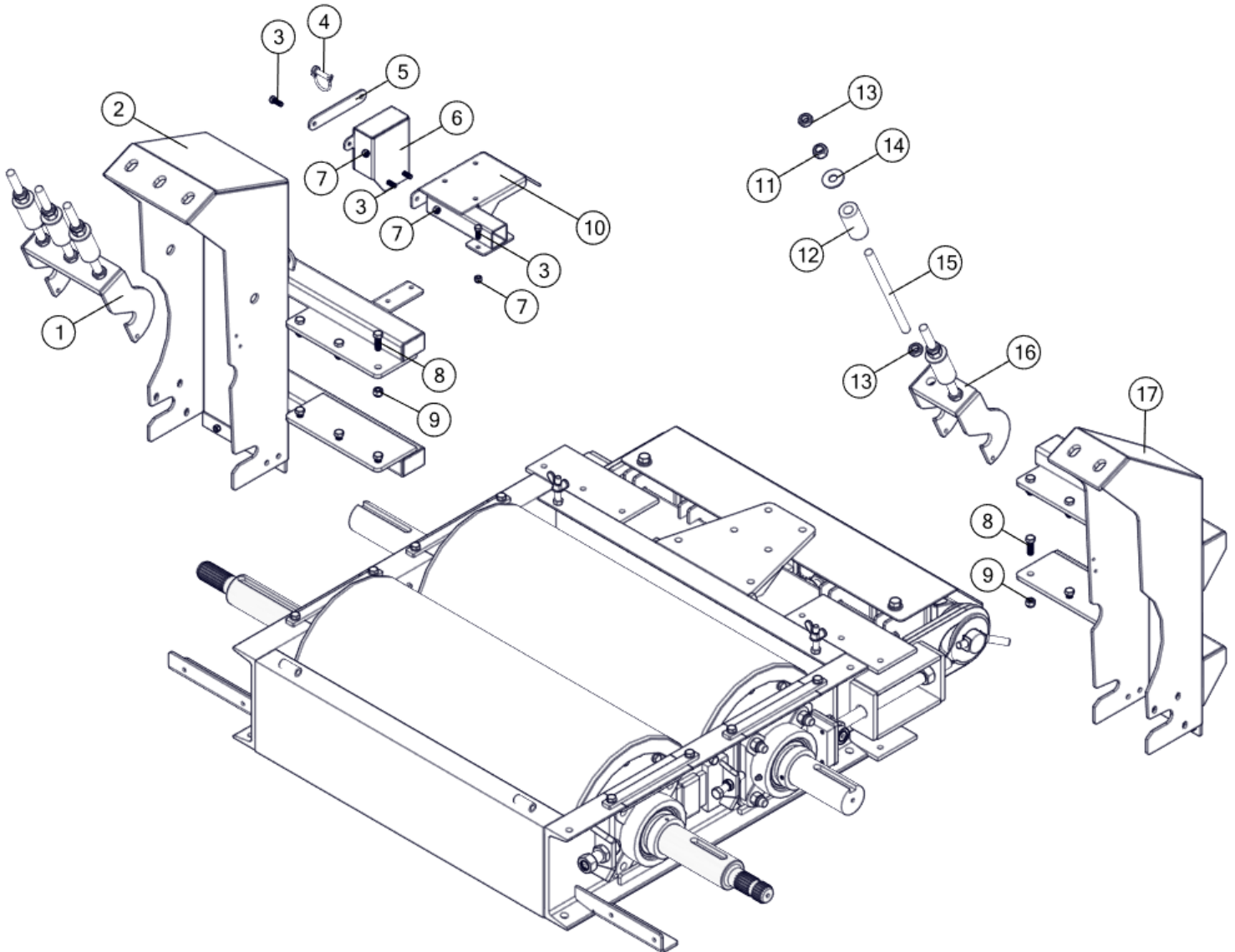

## 11 PARTS

### 11.3 Roller Mill - Upper Half

REF #	PART #	DESCRIPTION	QTY
1	168000-0544	Flat Washer - 1/2" SAE PLTD	2
2	167100-0995	Wing Nut 1/2" NC	2
3	615100-0765.00	Brg Hold-Down Bracket - Mill Frame - 2020	2
4	159400-0401	Hex Bolt - 1/2" NC x 1-1/2" Gr.5 PL	8
5	168600-0098	Lock Washer - 1/2" PL	8
6	615100-0526.00	Take Up Bearing Hold Down Bracket	2
7	159600-0420	Hex Bolt - Full Thread - 1/2" NC x 2" Gr.5 PL	2
8	167000-0650	Jam Nut - 1/2" NC Gr.5 PL	2
9	167200-0652	Nyloc Nut - 3/8" NC Gr.5 PL	4
10	168000-0540	Flat Washer - 3/8" SAE	4
11	159300-0961	Hex Bolt - 3/8" NC x 1" Gr.5 PL	4
12	615000-0829.00	36" Diff Mill Frame - Flange Brgs - 2020	1
13	773600-0802.01	36" Cast x 2-15-16 Shaft - Idler	1
14	773600-0395.00	36" Drive Roll - 2-15/16" B-Loc - gbox reduc	1
15	375000-0551	PTO Shaft - 55 Series with O/R Clutch 1000 rpm	1
16	614000-0229.00	Stop Bolt - 1" NF x 4-1/2" Full Thread	2
17	167000-0697	Jam Nut - 1" NF RH Gr.5 BL	2
18	159600-0535	Hex Bolt - Full Thread - 5/8" NC x 3-1/2" Gr.5 PL	2
19	167000-0658	Jam Nut - 5/8" NC Gr.5 PL	2
20	615100-0546.00	2 15/16" Bearing Slide - SCA non diff	2
21	114000-0255	Bearing - 4-Bolt Flange 2-15/16"	4
22	415100-0319.00	Bearing Push Plate	2
23	167200-0692	Nyloc Nut - 3/4" NC Gr.5 PL	8
24	615100-0527.00	Bearing Cam Base	2
25	168600-0071	Lock Washer - 3/8" PL	8
26	159300-0988	Hex Bolt - 3/8" NC x 1-1/2 Gr.5 PL	8
27	159400-0806	Hex Bolt - 3/4" NC x 2-1/2" Gr.5 PL	8
28	303000-0024	Mono Leaf Spring - 2pc	1
29	413600-0136.00	Spring Pressure Plate	1
30	167000-0705	Jam Nut - 1-1/4" NF Gr.5 PL RH	2
31	615100-0519.01	Spring Adjustment Bolt - 1-1/4" UNF	2

## 11 PARTS

### 11.3 Roller Mill - Upper Half

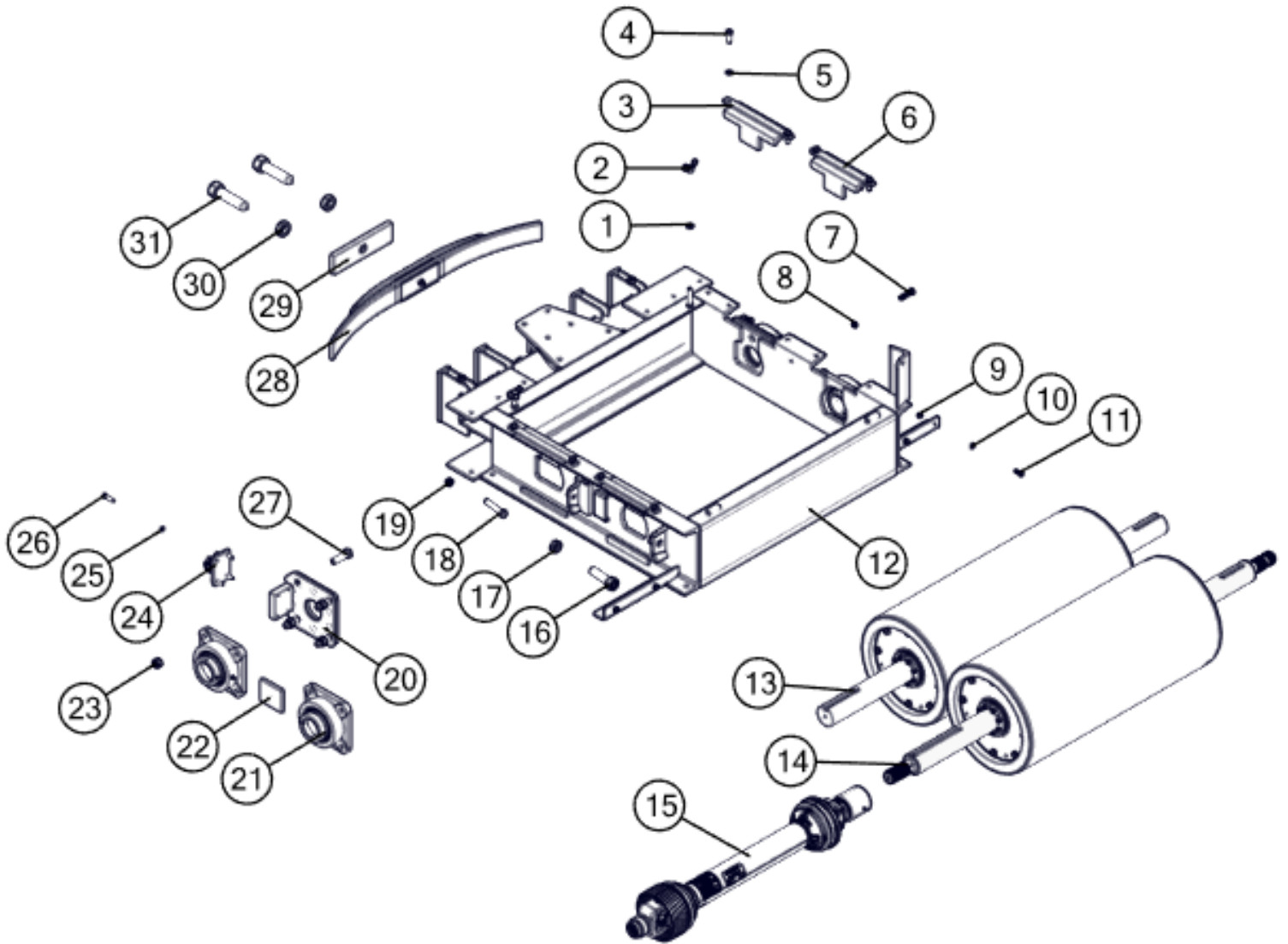

## 11 PARTS

### 11.4 Worm Drive Roll Adjustment

REF #	PART #	DESCRIPTION	QTY
1	159400-0636	Hex Bolt - 5/8" NC x 2-1/2" Gr.5 PL	8
2	615100-0516.01	Spring Cam Adjustment Box	1
3	168000-0580	Flat Washer - 5/8" SAE PL	10
4	167200-0690	Nyloc Nut - 5/8" NC Gr.5 PL	8
5	168000-0544	Flat Washer - 1/2" SAE PLTD	4
6	167200-0688	Nyloc Nut - 1/2" NC Gr.5 PL	4
7	414000-0582.00	3/16"Keystock x 1-1/2"	1
8	120000-0601	Steel Worm 6DP Single Start RH 7/8" ID	1
9	414000-0400.00	1/2" Keystock x 3"	1
10	121000-0632	Worm Gear - 6DP - Single Start, 30 Tooth, 1-15/16" Dia	1
11	415100-0524.01	Cam Shaft 1-15/16" Dia	1
12	168600-0120	Lock Washer - 5/8" PL	2
13	159400-0580	Hex Bolt - 5/8" NC x 1" GR5 PL	2
14	473600-0207.00	Cam Adjuster Shield	1
15	414000-0243.01	Worm Wheel Brake	1
16	168600-0098	Lock Washer - 1/2" PL	1
17	159400-0401	Hex Bolt - 1/2" NC x 1-1/2" Gr.5 PL	1
18	615100-0361.00	Worm Shaft - 7/8" x 11"-3/4"	1
19	113900-0914	7/8" Bearing - Pillow Block	2
20	413600-0114.00	Worm Gear Spacer	2
21	159400-0427	Hex Bolt - 1/2" NC x 2" Gr.5 PL	4
22	114000-0262	Bearing - Pillow Block 1-1/516" ID NTN (UELP-1.15/16M)	4
23	415100-0525.01	Cam Shaft Capping Washer	4
24	415100-0534.00	Pipe Bushing	2
25	167000-0697	Jam Nut - 1" NF RH Gr.5 BL	2
26	415100-0526.00	Outer Band - 3-5/16" x 4" x 2"	2
27	415100-0017.00	Oilite Bushing - 2-15/16" x 3-5/16" x 2"	2
28	415100-0533.00	Spring Cam Hub	2
29	415100-0022.00	Cam Position Indicator	1
30	161800-0010	Bent Pin - 5/8" x 3"	2

## 11 PARTS

### 11.4 Worm Drive Roll Adjustment

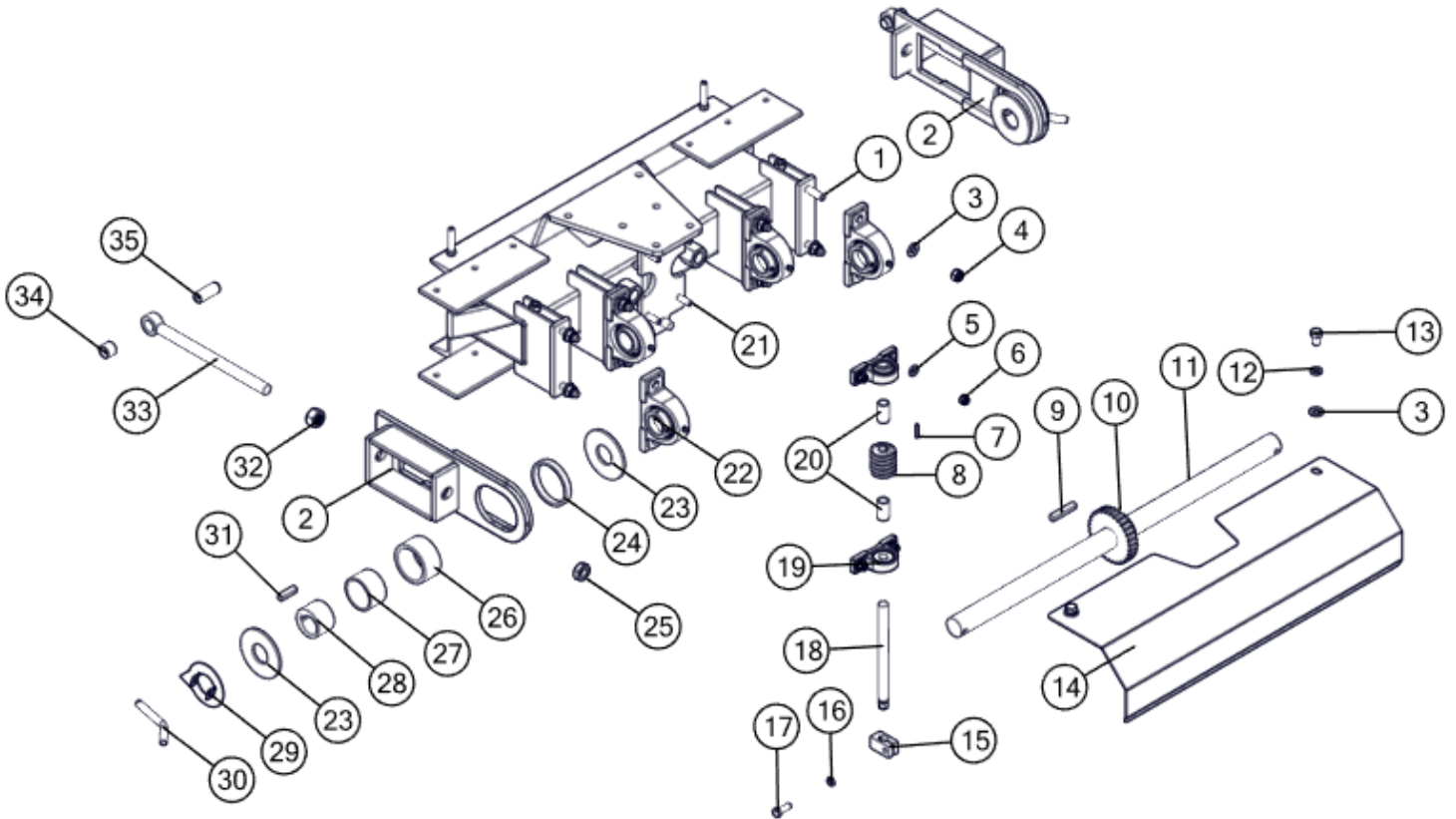

REF #	PART #	DESCRIPTION	QTY
31	414000-0881.00	1/2" Keystock x 2"	2
32	167000-0870	Hex Nut - 1" NF Gr.5 BL RH	2
33	615100-0703.00	Pivot Eye Rod	2
34	113500-0126	Oilite Bushing - 1" x 1-1/4" x 1"	2
35	414000-0239.00	Cam Pivot Pin - 1" x 2-1/2"	2

## 11 PARTS

### 11.5 Multi-Belt Differential Drive & Shield - Front

REF #	PART #	DESCRIPTION	QTY
1	144100-0828	V-Belt - CC128	8
2	159400-0401	Hex Bolt - 1/2" NC x 1-1/2" Gr.5 PL	2
3	167200-0688	Nyloc Nut - 1/2" NC Gr.5 PL	5
4	415000-0703.02	Idler Anchor Plate	1
5	114100-0021	1-1/4" Bearing - Cylindrical 72mm OD	4
6	124000-0020	Pulley - 8C7 Finished Bore - RA104 Brg Cavity	2
7	415000-0704.03	Outer Position Plate	1
8	168000-0544	Flat Washer - 1/2" SAE PLTD	6
9	159400-0410	Hex Bolt - 1/2" NC x 1-3/4" Gr.5 PL	2
10	615000-0702.00	Cross Shaft	1
11	159400-0427	Hex Bolt - 1/2" NC x 2" Gr.5 PL	1
12	143600-0416	Pulley - 8-Groove C x 16" - 'F' Series QD Bushing	1
13	415000-0745.01	3/4" Keystock x 4.25"	2
14	142100-0538	QD Bushing - 'F' Series - 2-15/16"	2
15	143600-0411	Pulley - 8-Groove C x 11" - 'F' Series QD Bushing	1
16	415000-0712.01	Idler Shaft	1
17	159300-0961	Hex Bolt - 3/8" NC x 1" Gr.5 PL	8
18	168000-0540	Flat Washer - 3/8" SAE	8
19	168600-0071	Lock Washer - 3/8" PL	8
20	674800-0121.01	Front Lower Shield Assembly - Diff Aux o Offset BH	1
**	159400-0110	Hex Bolt 7/16" NC x 1"	4
**	167200-0414	Top Lock Nut 7/16" NC	4
21	154000-0140	Overcenter Latch - 4.7"	2
**	159300-0520	Stove Bolt - #10-24 x 1/2"	6
**	167000-0520	Hex Nut - #10-24 PL	6
22	154000-0141	Catch - Overcenter Latch - 4.7"	2
**	159300-0520	Stove Bolt - #10-24 x 1/2"	4
**	167000-0520	Hex Nut - #10-24 PL	4
23	615000-0971.00	Front Fixed Shield	1
24	615000-0973.00	Mount Bracket - Front Section - Fixed Shield	1
25	615000-0972.00	Front Shield Rear Section	1

## 11 PARTS

### 11.5 Multi-Belt Differential Drive & Shield - Front

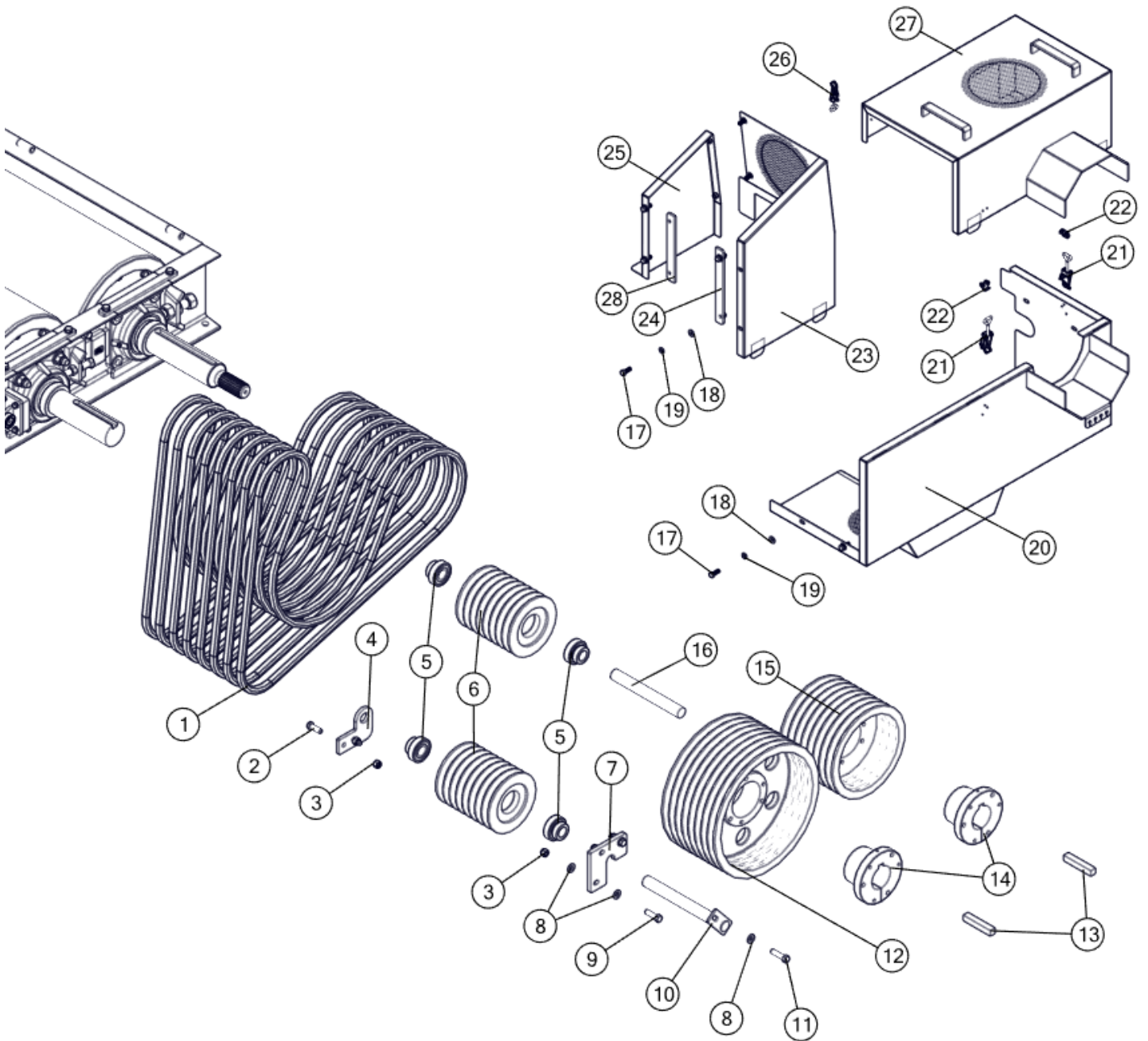

REF #	PART #	DESCRIPTION	QTY
26	154000-0142	Overcenter Latch - 3.5"	1
**	159300-0515	Stove Bolt - 8-32 x 1/2"	2
**	167000-0519	Hex Nut - 8-32 PL	2
27	674800-0104.00	Front Shield Upper Assembly	1
28	615000-0974.00	Mount Bracket - Rear Section - Fixed Shield 2014	1

## 11 PARTS

### 11.6 Multi-Belt Differential Drive - Rear

REF #	PART #	DESCRIPTION	QTY
1	144100-0828	V-Belt - CC128	4
2	159400-0401	Hex Bolt - 1/2" NC x 1-1/2" Gr.5 PL	2
3	167200-0688	Nyloc Nut - 1/2" NC Gr.5 PL	5
4	415000-0703.02	Idler Anchor Plate	1
5	114100-0021	1-1/4" Bearing - Cylindrical 72mm OD	4
6	124000-0021	Pulley - 4-Groove 7" x 2-5/8"	2
7	415000-0704.03	Outer Position Plate	1
8	168000-0544	Flat Washer - 1/2" SAE PLTD	3
9	159400-0410	Hex Bolt - 1/2" NC x 1-3/4" Gr.5 PL	2
10	615000-0802.00	Cross Shaft Assembly	1
11	159400-0427	Hex Bolt - 1/2" NC x 2" Gr.5 PL	1
12	143600-0116	Pulley - 4 Groove 16" - E Series	1
13	142100-0120	Bushing - E Series - 2-15/16"	2
14	143600-0110	Pulley - 4 Groove 11" - E Series	1
15	415000-0805.01	Idler Shaft - 4 Belt	1



## 11 PARTS

### 11.6 Multi-Belt Differential Drive - Rear

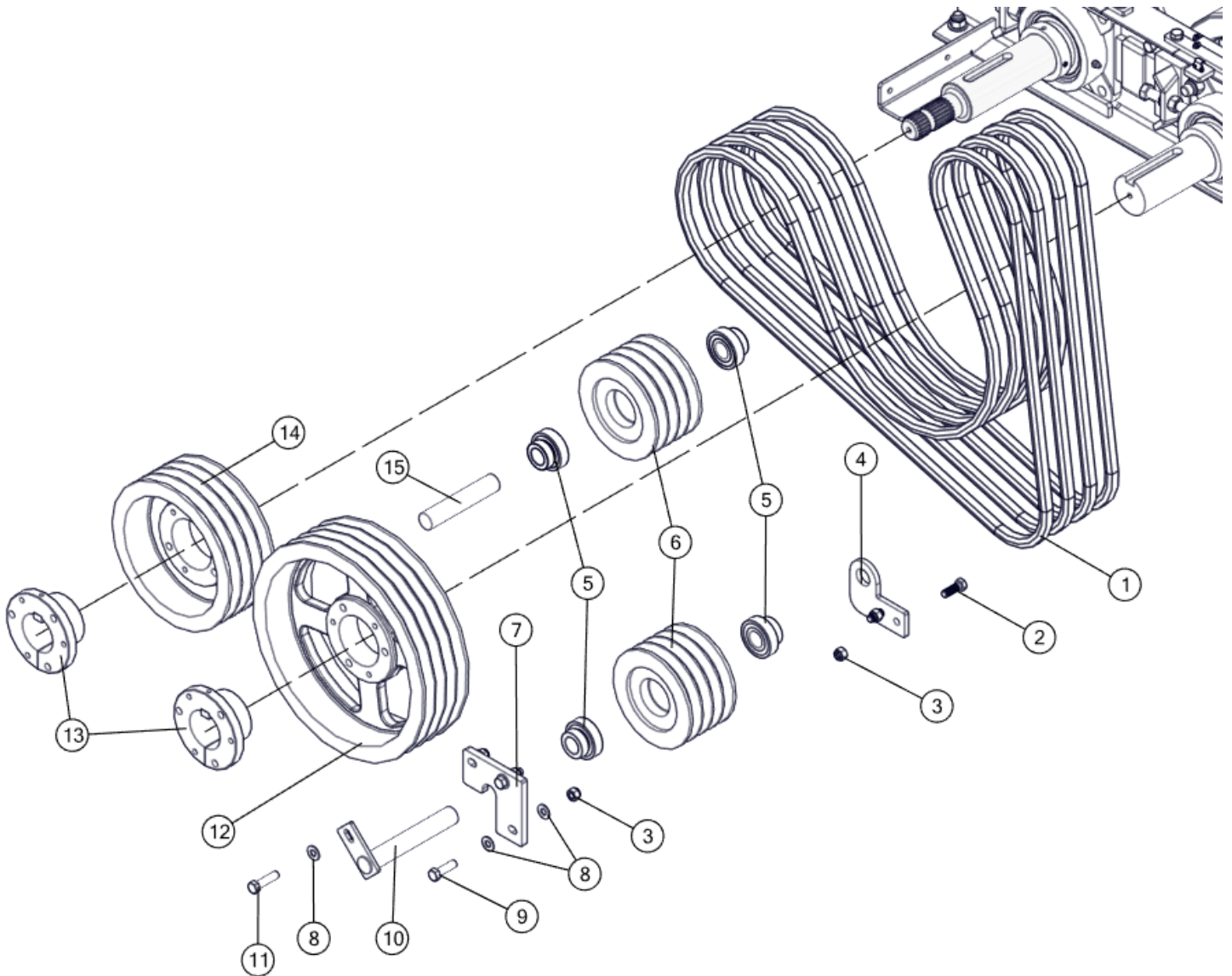

## 11 PARTS

### 11.7 Multi-Belt Differential Shield - Rear

REF #	PART #	DESCRIPTION	QTY
1	615000-0830.00	Rear Shield Weld't - Main Top Section - 4 Belt - Aux	1
2	159300-0961	Hex Bolt - 3/8" NC x 1" Gr.5 PL	17
3	168600-0071	Lock Washer - 3/8" PL	15
4	168000-0540	Flat Washer - 3/8" SAE	17
5	615000-0982.00	Rear Section - Rear Fixed Shield - 4 Belt	1
6	615000-0974.00	Mount Bracket - Rear Section - Fixed Shield 2014	1
7	615000-0973.00	Mount Bracket - Front Section - Fixed Shield	2
8	615000-0981.01	Rear Shield - 4 Belt - Front Section	1
9	154000-0142	Overcenter Latch - 3.5"	2
**	159300-0515	Stove Bolt - 8-32 x 1/2"	4
**	167000-0519	Hex Nut - 8-32 PL	4
10	154000-0141	Catch - Overcenter Latch - 4.7"	2
**	159300-0520	Stove Bolt - #10-24 x 1/2"	4
**	167000-0520	Hex Nut - #10-24 PL	4
11	154000-0140	Overcenter Latch - 4.7"	2
**	159300-0520	Stove Bolt - #10-24 x 1/2"	6
**	167000-0520	Hex Nut - #10-24 PL	6
12	167200-0652	Nyloc Nut - 3/8" NC Gr.5 PL	2
13	473600-0291.00	Top Panel - PTO Aux Shield	1
14	154000-0143	Catch - Overcenter Latch - 3.5"	1
**	159300-0515	Stove Bolt - 8-32 x 1/2"	2
**	167000-0519	Hex Nut - 8-32 PL	2
15	414000-0906.01	Lap Flat	1
16	153000-0800	Butt Hinge - 2" x 1-1/2"	2
**	159300-0501	Stove Bolt - #10-24 x 5/8"	8
**	167000-0520	Hex Nut - #10-24 PL	8
17	673600-0156.00	Lower Panel Weldment - PTO Aux Shield	1
18	615000-0831.00	Lower Rear Shield Weld't - 4 Belt - Offset BH	1
19	474800-0096.01	Bottom Guard - 4 Belt	1

# 11 PARTS

## 11.7 Multi-Belt Differential Shield - Rear

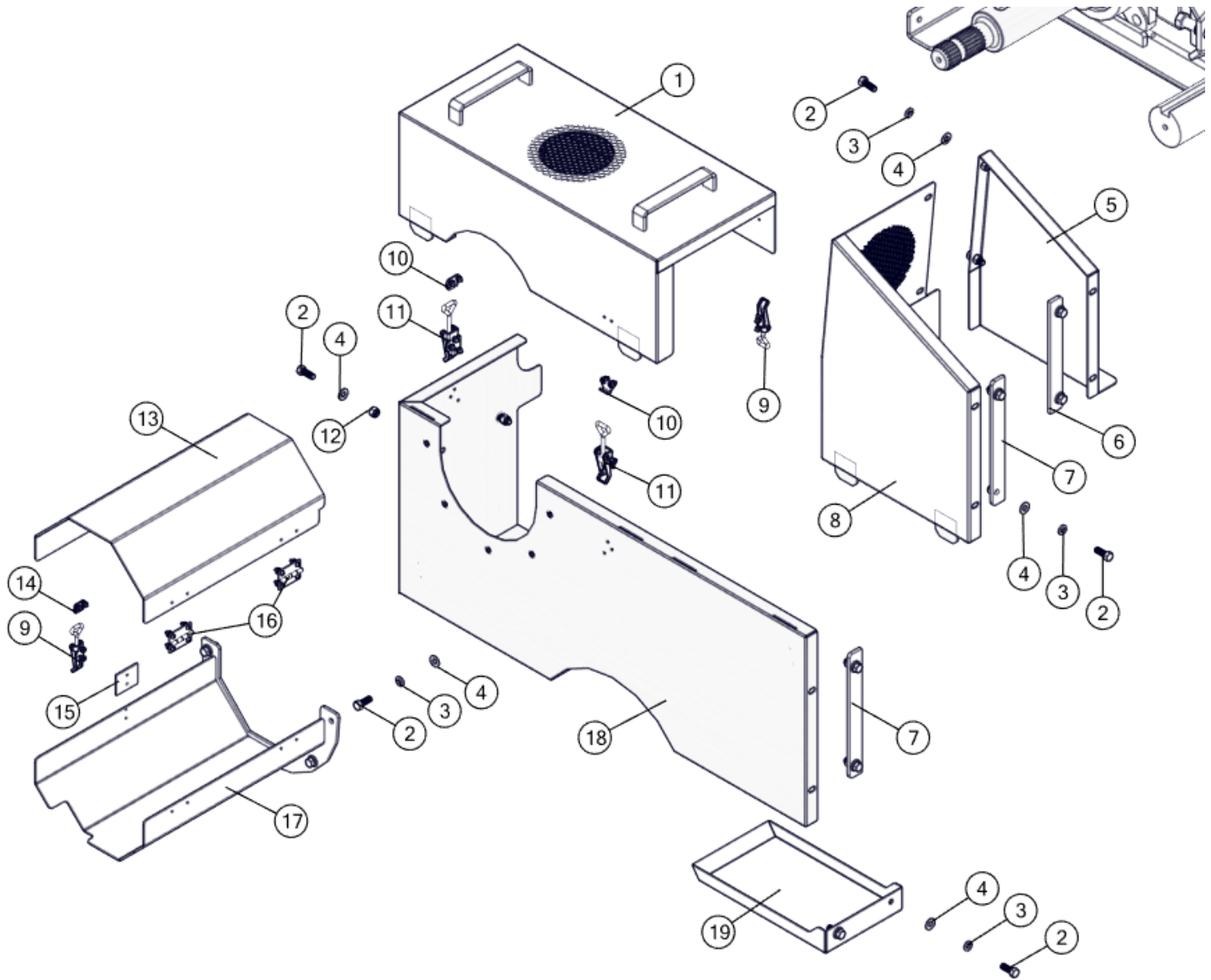

## 11 PARTS

### 11.8 Bottom Hopper

REF #	PART #	DESCRIPTION	QTY
1	673600-0071.02	Rear Panel Weldment	1
2	159400-0401	Hex Bolt - 1/2" NC x 1-1/2" Gr.5 PL	16
3	167200-0688	Nyloc Nut - 1/2" NC Gr.5 PL	16
4	167200-0652	Nyloc Nut - 3/8" NC Gr.5 PL	32
5	673600-0096.00	Inspection Plate - Bottom Hopper	1
6	673600-0028.00	Spreader Frame Rail	2
7	147000-0010	Manual Canister	1
8	159300-0735	Hex Bolt - 5/16" NC x 1" Gr.5 PL	2
9	168000-0040	Flat Washer - 5/16" USS PL	2
10	167200-0648	Nyloc Nut - 5/16" NC Gr.5 PL	2
11	673600-0072.04	Front Panel Weldment	1
12	167000-0809	Hex Nut - 1/2" NC Gr.5 PL	1
13	412400-0532.02	Tensioner Bracket	1
14	167000-0650	Jam Nut - 1/2" NC Gr.5 PL	2
15	412400-0518.04	1/2" Spacer - Idler Tensioner	2
16	163100-0120	Carriage Bolt - 1/2" NC x 6" Gr.5 BL	1
17	167200-0690	Nyloc Nut - 5/8" NC Gr.5 PL	2
18	114100-0016	1" Bearing - 52mm Cylindrical OD	2
19	415400-0141.03	Sleeve - 3-1/2" Triple Idler Pulley	1
20	167200-0692	Nyloc Nut - 3/4" NC Gr.5 PL	1
21	168000-0587	Flat Washer - 3/4" SAE PL	1
22	124000-0017	Idler Pulley - 3-5/8" OD x 52mm Bore	1
23	168000-0080	Flat Washer - 5/8" USS PL	2
24	474800-1087.02	Tensioner Slide Bracket - Offset BH	1
25	163100-0145	Carriage Bolt - 3/4" NC x 4-1/2" Gr.5 PL	1
26	415400-0015.00	0.75" Spacer Bar - Idler Assembly	1
27	163000-0507	Carriage Bolt - 3/8" NC x 1" Gr.5 PL	24
28	673600-0118.00	Wrap - Bottom Hopper	1

# 11 PARTS

## 11.8 Bottom Hopper

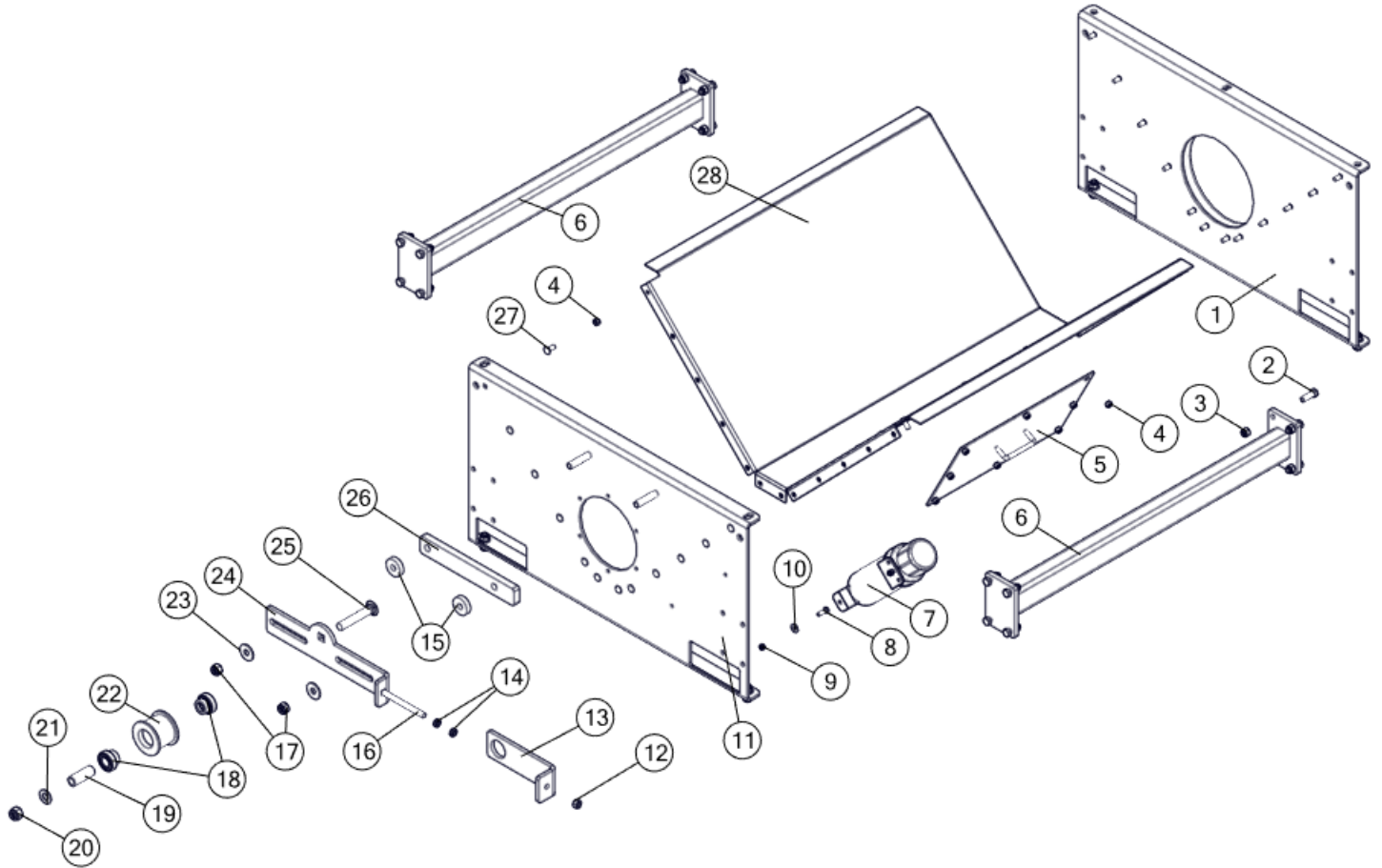

## 11 PARTS

### 11.9 Cross Auger Assembly

REF #	PART #	DESCRIPTION	QTY
1	155500-0100	Band Clamp - 10"	1
2	673600-0102.00	Extension Tube - Transition - gbox red	1
3	167200-0652	Nyloc Nut - 3/8" NC Gr.5 PL	8
4	159300-0961	Hex Bolt - 3/8" NC x 1" Gr.5 PL	14
5	167200-0688	Nyloc Nut - 1/2" NC Gr.5 PL	4
6	168000-0544	Flat Washer - 1/2" SAE PLTD	8
7	159400-0401	Hex Bolt - 1/2" NC x 1-1/2" Gr.5 PL	4
8	673600-0103.01	10" Cross Auger - gbox reduc - diff aux	1
9	168600-0071	Lock Washer - 3/8" PL	6
10	673600-0083.00	Bearing Mount Plate - 1-1/4" Bore	1
11	114000-0320	1-1/4" - 4-Bolt Flange Bearing	1
12	144500-0750	5VX 750 Belt	3
13	142000-0220	Taper Bushing SF 2-15/16"	1
14	414000-0399.00	1/4" Keystock x 3"	1
15	142100-0025	Taper Bushing - E114	1
16	143300-0125	Pulley - 3 Groove 12.5"	1
17	143300-0073	Pulley - 3 Groove 7.53" - SF	1
18	159400-0628	Hex Bolt - 5/8" NC x 2" Gr.5	4
19	168000-0580	Flat Washer - 5/8" SAE PL	8
20	167200-0690	Nyloc Nut - 5/8" NC Gr.5 PL	4

## 11 PARTS

### 11.9 Cross Auger Assembly

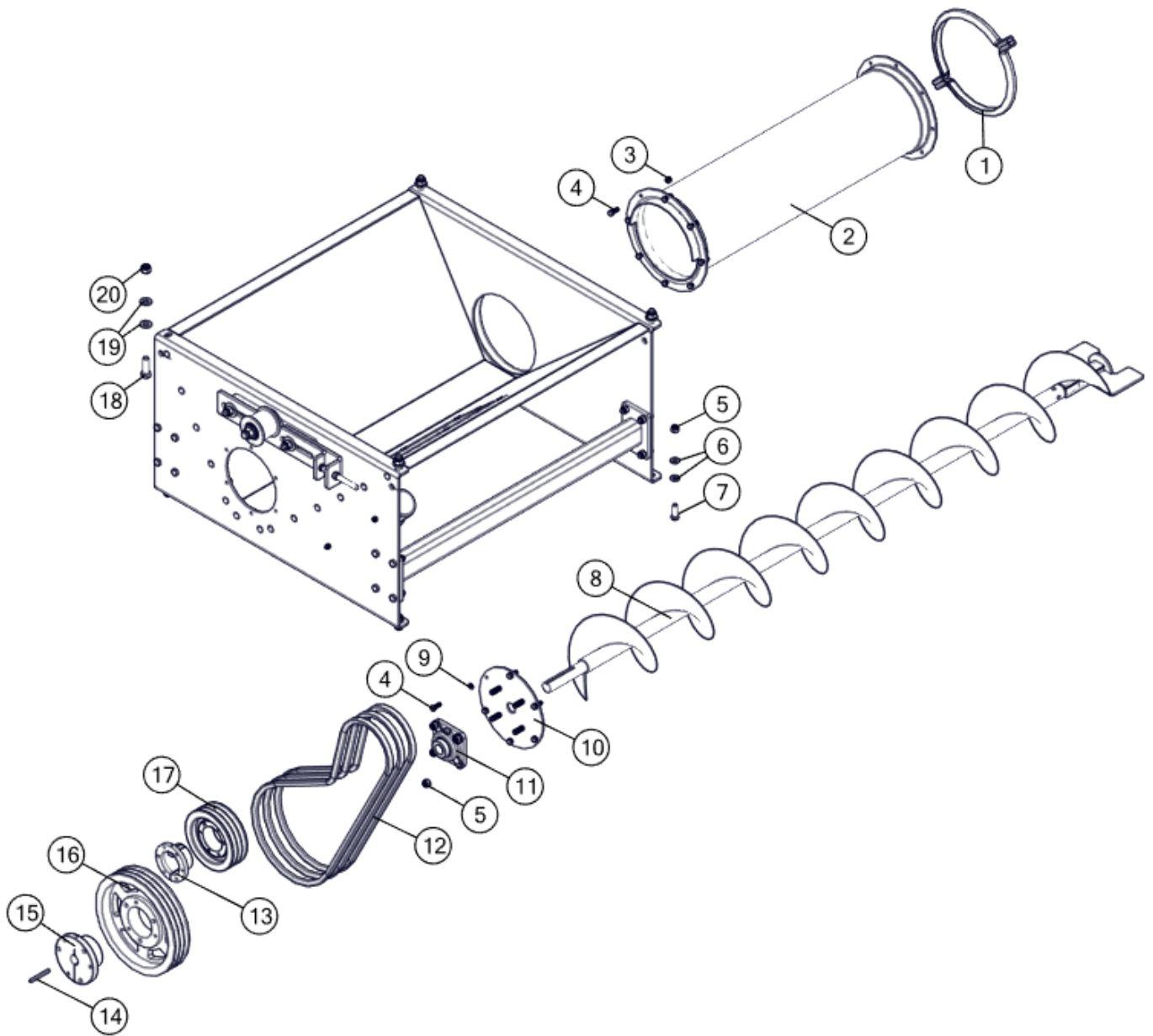

## 11 PARTS

### 11.10 Drive Box

REF #	PART #	DESCRIPTION	QTY
1	470000-1341.00	Output Shield - Belt Reduction	1
2	374000-0009	PTO Adaptor - 1-3/4" 20-Spline x 1-3/8" 21-Spline	1
3	374000-0006	PTO Adaptor - 1-3/4" 20-Spline x 1-3/8" 6-Spline	1
4	114000-0262	Bearing - Pillow Block 1-1/516" ID NTN (UELP-1.15/16M)	2
5	670000-0566.00	End Cover Shield Weldment - Belt Speed Reduction 2022	1
6	167200-0690	Nyloc Nut - 5/8" NC Gr.5 PL	8
7	168000-0580	Flat Washer - 5/8" SAE PL	8
8	159400-0634	Hex Bolt 5/8" NC x 2-1/4" Gr.5 PL	4
9	470000-0933.00	1/2" x 3" KS - Transfer Box	1
10	470000-1338.00	Input Shaft - Belt Reduction	1
11	380200-0177	Series 55 - 1-3/4" 20 Spline Slide Lock Yoke	2
12	380000-0055	55E Cross & Bearing Kit	2
13	380400-0056	Series 55 Yoke - Double Center Assembly	2
14	159400-0430	Hex Bolt 1/2" NC x 2-1/2" Gr.5 PL	6
15	474800-1253.00	7" x 1.25" Spacer - 55S Double Center (55311-1000)	1
16	167200-0416	1/2" Top Lock Nut	6
17	670000-0569.00	Base Weldm't (15deg) Belt Speed Reduction 2023	1
18	159400-0628	Hex Bolt 5/8" NC x 2" Gr.5	4



## 11 PARTS

### 11.10 Drive Box

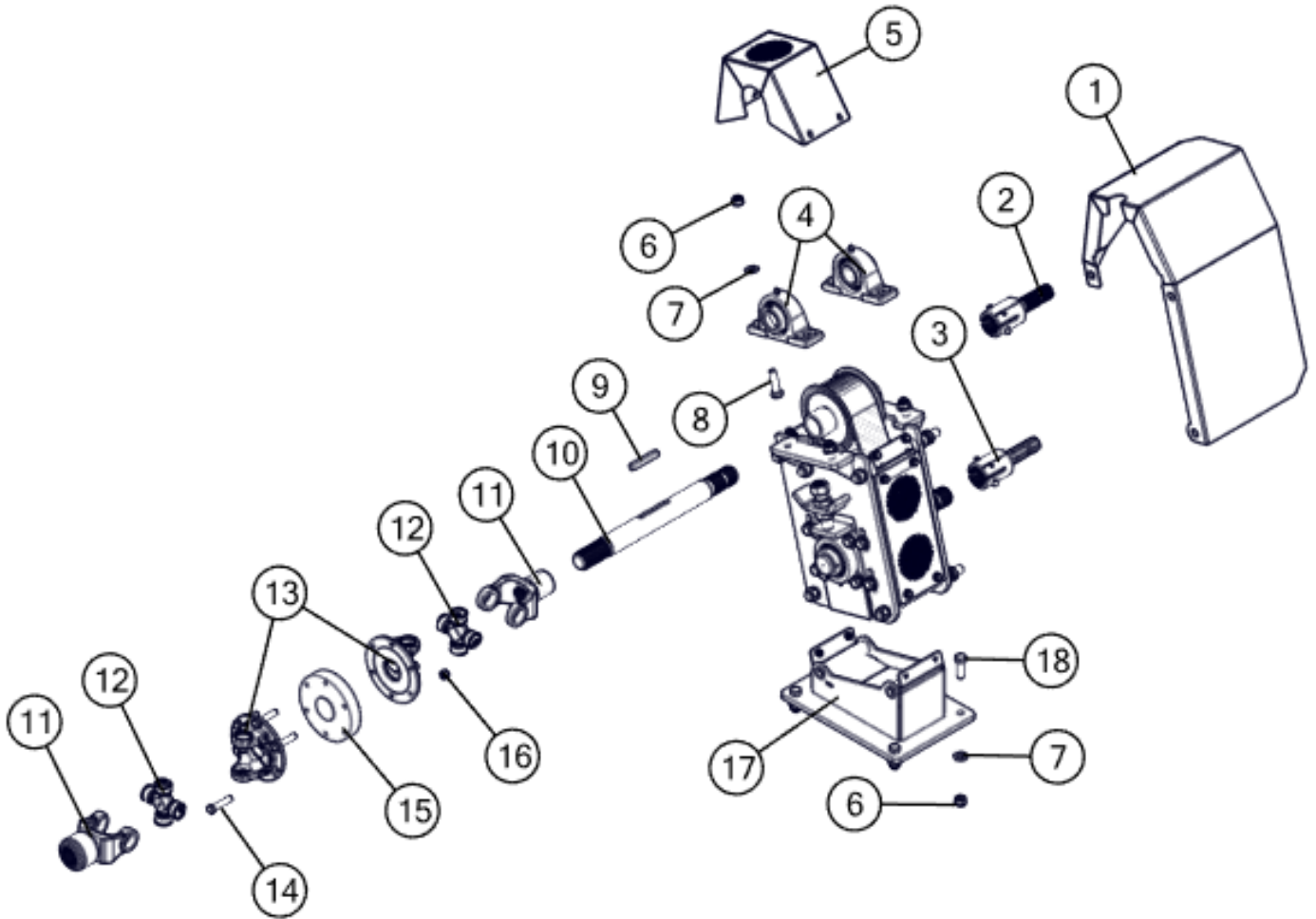

## 11 PARTS

### 11.10.1 Drive Box Assembly

REF #	PART #	DESCRIPTION	QTY
1	167000-0835	Hex Nut - 3/4" NC Gr.5 PL	10
2	168600-0127	Lock Washer - 3/4" NC PL	13
3	470000-1259.00	Cross Rod - Belt Reduction	2
4	470000-1132.00	Output Shaft - Belt Reduction	1
5	144700-0743	48" SC (34-63 Belt Reduc)	1
6	474900-0842.00	34-14MX90-6F MPB Timing Pulley - Finished Bore 1.94	1
7	143600-0011	63-14MX90-AF 4030 Timing Pulley	1
8	142500-0104	Taper-Lock Bushing - 1-15/16" Bore (4030)	1
9	670000-0550.00	Back Plate Assy - Pedestal Assy	1
10	670000-0565.00	Side Shield - Belt Speed Reduction - 2022	1
11	670000-0563.00	Lower Bolt Bar Weldt - Speed Reduction Box 2022	2
12	470000-1268.00	Cover Plate	2
13	159400-0628	Hex Bolt - 5/8" NC x 2" Gr.5	8
14	670000-0551.00	Front Plate Assy - Pedestal	1
15	167000-0697	Jam Nut - 1" NF RH Gr.5 BL	2
16	670000-0556.00	Tension Adjuster Bolt 1" NF x 4-3/4" L	2
17	168600-0120	Lock Washer - 5/8" PL	16
18	114000-0250	Bearing - 4-Bolt Flange 1-15/16" ID NTN (UELFU-1.15/16M)	2
19	670000-0564.00	Bearing Slide Plate Assy - Speed Reduction 2022	2
20	159400-0595	Hex Bolt - 5/8" NC x 1-3/4" Gr 5 PL	8
21	168000-0580	Flat Washer - 5/8" SAE PL	8
22	670000-0562.00	Upper Bolt Bar Weldt- Speed Reduction Box 2022	2
23	670000-0554.00	Shield Transition Weldment	2
24	168000-0540	Flat Washer - 3/8" SAE	12
25	168600-0071	Lock Washer - 3/8" PL	12
26	159300-0944	Hex Bolt - 3/8" NC x 3/4" Gr.5 PL	12
27	470000-1193.00	Bushing Pipe - Spanner - Belt Reduction	5
28	470000-1266.00	Spacing Pipe - Belt Reduction	2
29	470000-0933.00	1/2" x 3" KS - Transfer Box	1
30	470000-1258.01	Cross Rod - Belt Reduction	3
31	167000-0675	Jam Nut - 3/4" NC Gr.5 PL	3

# 11 PARTS

## 11.10.1 Drive Box Assembly

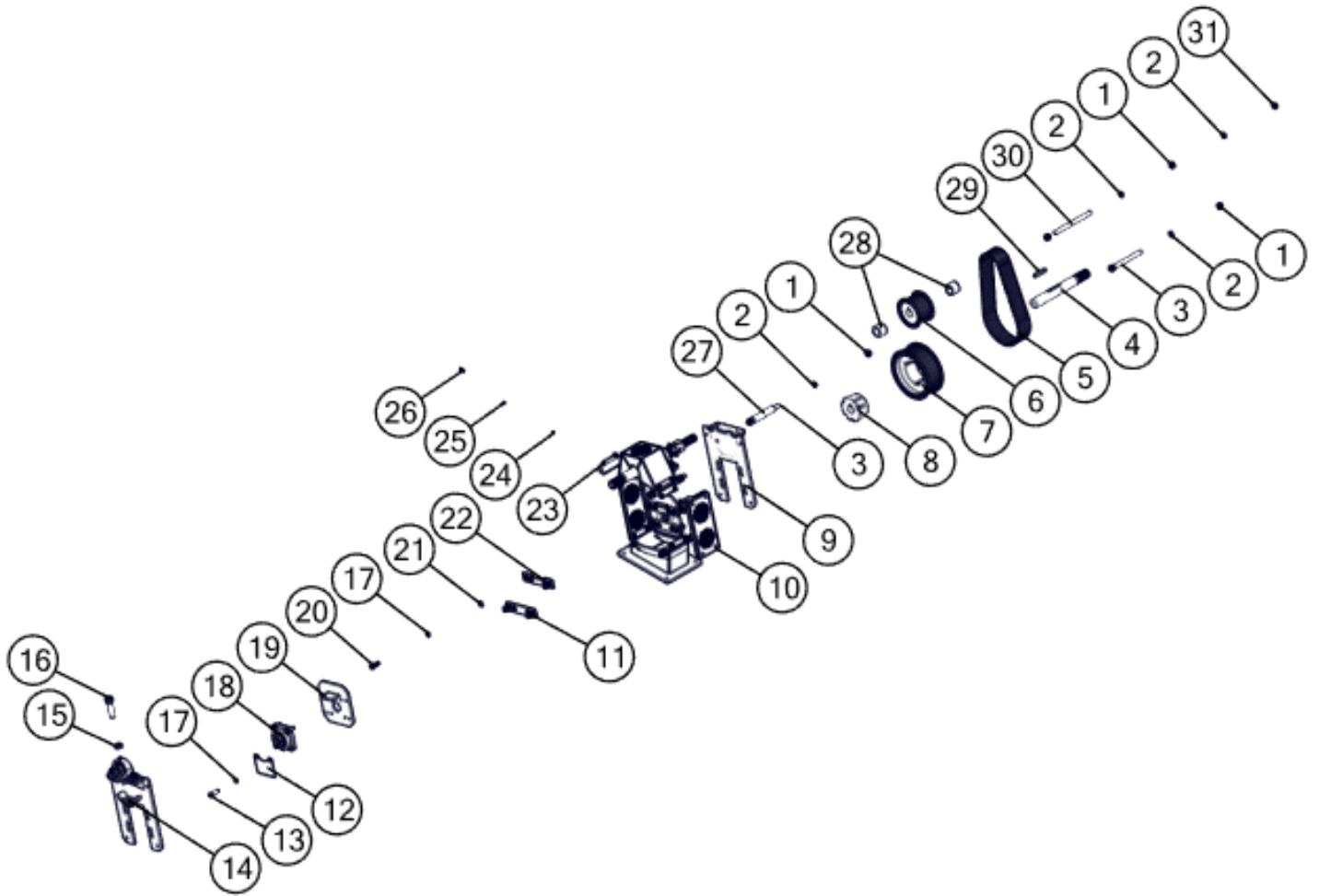

## 11 PARTS

### 11.11 Trailer Assembly

REF #	PART #	DESCRIPTION	QTY
1	159400-0401	Hex Bolt - 1/2" NC x 1-1/2" Gr.5 PL	4
2	167200-0688	Nyloc Nut - 1/2" NC Gr.5 PL	6
3	161500-0505	Safety Pin - 1/8"	1
4	673600-0157.00	Transport Auger Rest - 12" Feed Auger	1
5	147000-0601	LED Dual Tail Light Kit - Right	1
6	167200-0694	Nyloc Nut - 1" NC Gr.5 PL	2
7	343000-0201	Perfect Hitch Complete - Auxiliary Mill	1
8	159500-0075	Hex Bolt - 1" NC x 6-1/2" Gr5	2
9	147000-0600	LED Dual Tail Light Kit - Left	1
10	474800-1219.00	812 Spindle - 2.5 x 18SP w/ Nut & Washer - Drilled	2
11	100100-0603	12.5L - 15FI-I Tire/Rim 8 Bolt Rim	2
12	340800-0812	Wheel Hub Complete	2
13	159400-0488	Hex Bolt - 1/2" NC x 4" Gr.5 PL	2
14	673600-0155.00	36" Diff Drive Aux , Mech'l Disch, RedBox	1
15	341100-0050	Jack - 7000lb x 10" - Side Wind	1
16	159400-0628	Hex Bolt - 5/8" NC x 2" Gr.5	1
17	168000-0580	Flat Washer - 5/8" SAE PL	2
18	167200-0690	Nyloc Nut - 5/8" NC Gr.5 PL	1
19	140000-0490	Safety Chain	1
20	159400-0819	Hex Bolt - 3/4" NC x 6-1/2" Gr.5 PL	2
21	343000-0299	Base Hitch/Clevis Assembly Cat. 2	1
22	167200-0692	Nyloc Nut - 3/4" NC Gr.5 PL	2
23	167200-0652	Nyloc Nut - 3/8" NC Gr.5 PL	5
24	159300-0961	Hex Bolt - 3/8" NC x 1" Gr.5 PL	4
25	159600-0325	Hex Bolt 3/8" NC x 2-1/2" Full Thread	1
26	614000-0301.00	PTO Stand	1
27	480100-0722.01	Hose Clamp	1
28	670000-0525.00	Hydraulic Hose Stand	1

# 11 PARTS

## 11.11 Trailer Assembly

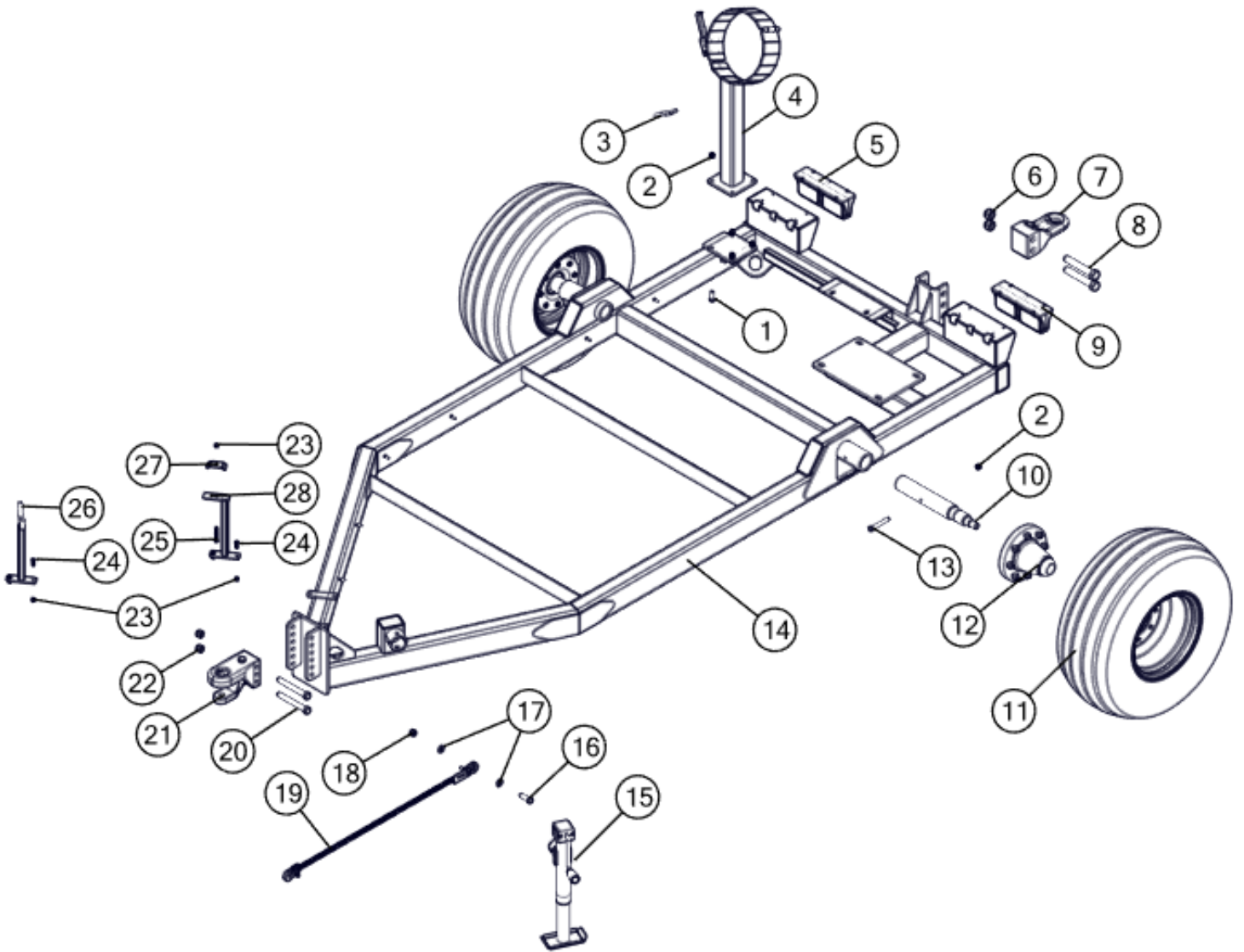

## 11 PARTS

### 11.11.1 Hub Assembly (340800-0812)

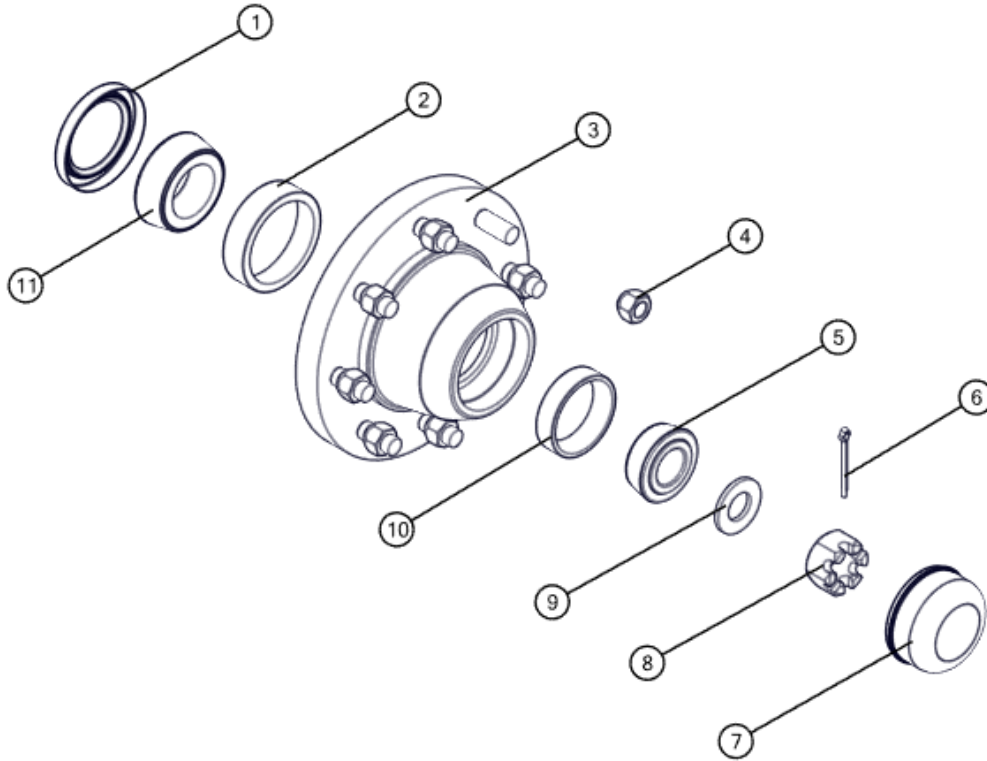

REF #	PART #	DESCRIPTION	QTY
1	340100-0017	Seal	1
2	115000-0040	Inner Cup	1
3	340000-0812	Hub 8 Bolt, 8"PCD, 6" Pilot	1
4	340300-0010	Wheel Bolt 1/2"-20 UNF x 1-1/4"	1
5	114500-0019	Outer Cone	1
6	170000-0200	Cotter Pin - 3/16" x 2"	1
7	340200-0017	Dust Cap	1
8	340700-0033	Spindle Nut - 1" x 14 UNF	1
9	168000-0598	Flat Washer - 1" SAE PL	1
10	115000-0019	Outer Cup	1
11	114500-0040	Inner Cone	1

**THIS PAGE INTENTIONALLY LEFT  
BLANK**

## 11 PARTS

### 11.12 Discharge Auger

#### 11.12.1 Discharge Auger - Tube and Flighting

REF #	PART #	DESCRIPTION	QTY
1	670000-0032.00	Rotating Handle Weldment	1
2	167200-0690	Nyloc Nut - 5/8" NC Gr.5 PL	1
3	159400-0725	Hex Bolt - 5/8" NC x 4-1/2" Gr.5 PL	1
4	670000-0150.01	Swivel Head Weldment - 12" Mechanical discharge	1
5	670000-0151.00	12" x 8' Mech. Discharge II Auger - with swivel	1
6	168000-0540	Flat Washer - 3/8" SAE	2
7	167200-0652	Nyloc Nut - 3/8" NC Gr.5 PL	6
8	159300-0944	Hex Bolt - 3/8" NC x 3/4" Gr.5 PL	4
9	671300-0084.00	Lower Panel Weld't - 12" Slide-on Chute	1
10	471300-0411.00	Upper Panel - 12" Chute	1
11	172200-0793	Spring Pin - 5/16" x 2"	1
12	114000-0320	1-1/4" - 4-Bolt Flange Bearing	1
13	167200-0688	Nyloc Nut - 1/2" NC Gr.5 PL	8
14	159400-0401	Hex Bolt - 1/2" NC x 1-1/2" Gr.5 PL	6
15	155500-0120	Band Clamp - 12"	1
16	670000-0226.00	12" x 8' Disch Auger Tube - Mech'l - Swivel Head (2021)	1
17	470000-1139.00	P.S. Support Arm - GBX Red Model	1
18	470000-1138.00	D.S. Support Arm - GBX Red Model	1



# 11 PARTS

## 11.12.1 Discharge Auger - Tube and Flighting

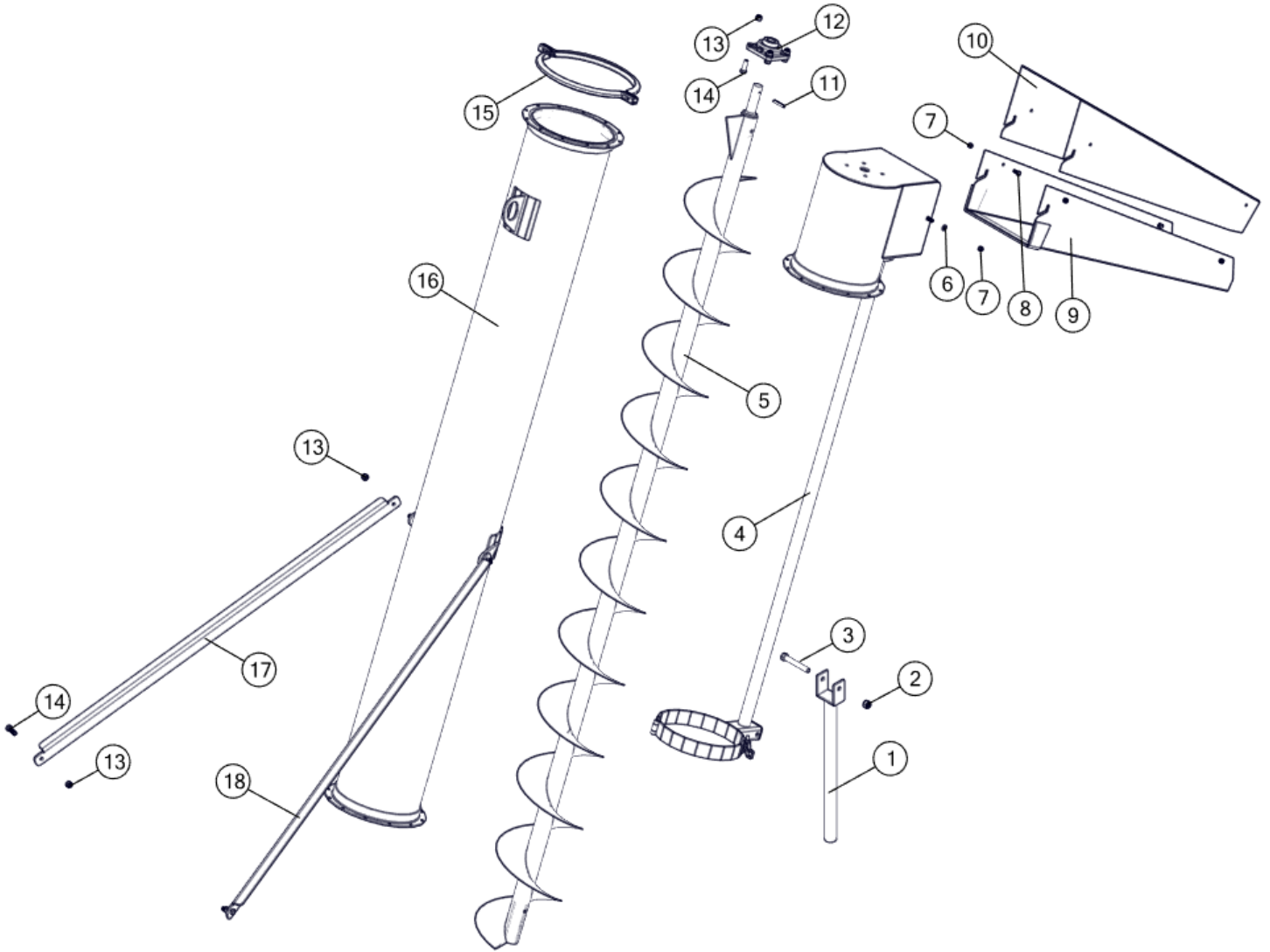

## 11 PARTS

### 11.12.2 Discharge Auger - Gear Box

REF #	PART #	DESCRIPTION	QTY
1	155500-0100	Band Clamp - 10"	1
2	167200-0688	Nyloc Nut - 1/2" NC Gr.5 PL	4
3	159400-0401	Hex Bolt - 1/2" NC x 1-1/2" Gr.5 PL	4
4	473000-0070.00	Mount Plate - Gearbox	1
5	159300-0979	Hex Bolt - 3/8" NC x 1-1/4" Gr.5 PL	8
6	168600-0071	Lock Washer - 3/8" PL	10
7	342100-0624	112deg Superior Gearbox - Model R20A - Square Shafts	1
8	473000-0071.00	Mount Plate - Gearbox	1
9	670000-0088.00	10" - 12" Mech. Gearbox II Weldment	1
10	155500-0120	Band Clamp - 12"	1
11	670000-0048.00	10" - 12" Gearbox Door	1
12	159300-0944	Hex Bolt - 3/8" NC x 3/4" Gr.5 PL	4
13	167100-0979	Wing Nut - 3/8" NC PL	2
14	167200-0652	Nyloc Nut - 3/8" NC Gr.5 PL	2

# 11 PARTS

## 11.12.2 Discharge Auger - Gear Box

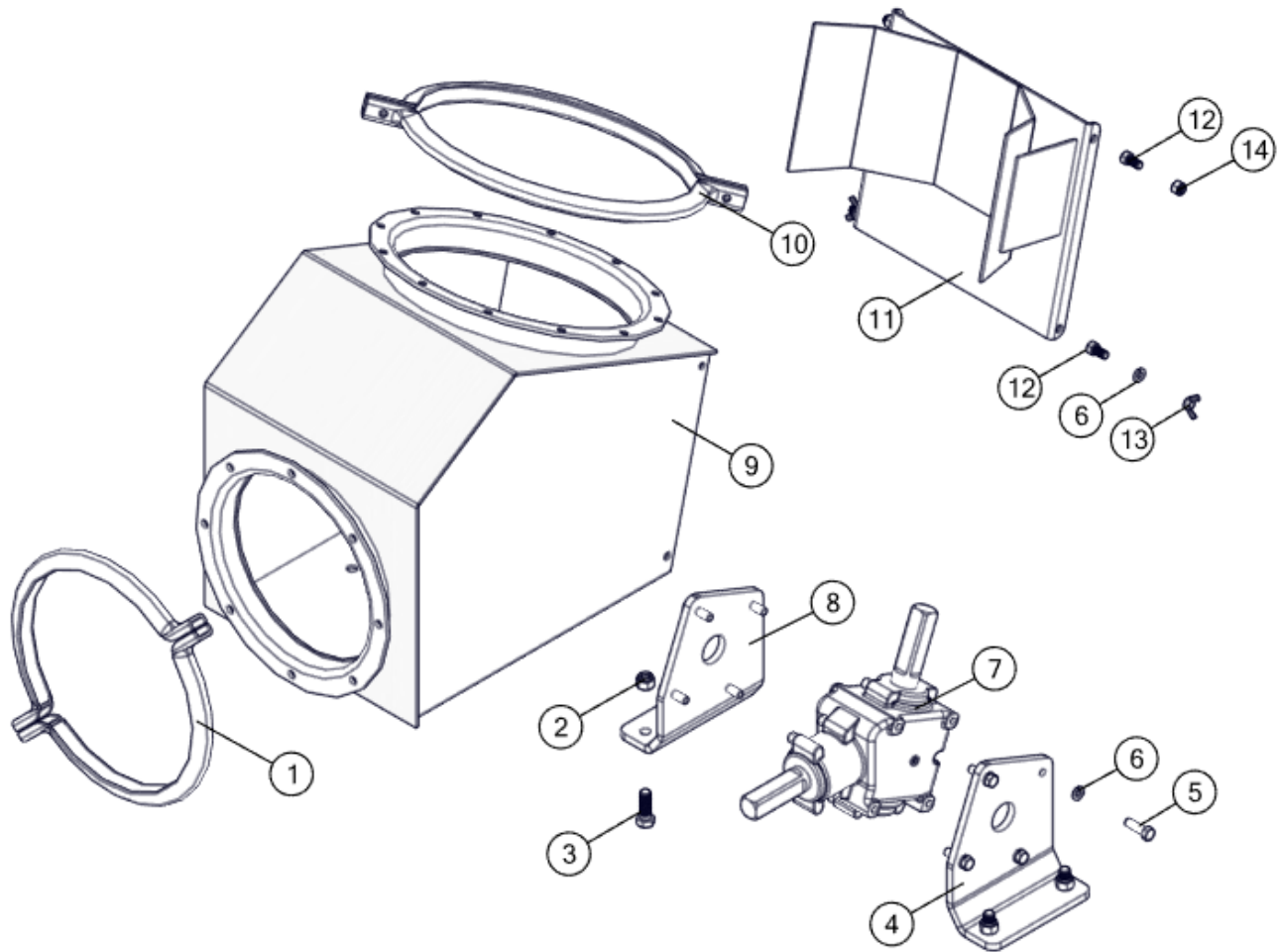

## 11 PARTS

### 11.13 Transfer Auger

#### 11.13.1 Transfer Auger - Lift and Swing Pedestal

REF #	PART #	DESCRIPTION	QTY
1	167200-0694	Nyloc Nut - 1" NC Gr.5 PL	1
2	168000-0139	Flat Washer - 1" USS PL	1
3	670000-0523.00	Tee Post - Lift and Swing	1
4	167200-0652	Nyloc Nut - 3/8" NC Gr.5 PL	1
5	471300-1471.00	Hex Bolt Locking Plate - 1"	1
6	159300-0979	Hex Bolt - 3/8" NC x 1-1/4" Gr.5 PL	1
7	159500-0080	Hex Bolt - 1" NC x 8-1/2" Gr5	1
8	114000-0250	Bearing - 4-Bolt Flange 1-15/16" ID NTN (UELFU-1.15/16M)	2
9	159400-0636	Hex Bolt - 5/8" NC x 2-1/2" Gr.5 PL	8
10	159400-0007	Hex Bolt - 3/8" NC x 3-1/2" NC Gr.5 PL	1
11	470000-0254.05	Base - Hose Clamp - Trans Auger Hyd L&S	1
12	480100-0722.01	Hose Clamp	1
13	480100-0710.01	Hose Clamp	1
14	167200-0690	Nyloc Nut - 5/8" NC Gr.5 PL	10
15	159400-0628	Hex Bolt - 5/8" NC x 2" Gr.5	2
16	614000-0519.00	Tower Weldment - L&S Bolt-on - 36" - 60" Mill	1
17	674800-0071.01	Vertical Post Lug- HD L&S	1
18	107000-0103	Cylinder Pin - 1" Dia x 3"	1
19	674800-0017.00	Cylinder Lug Weldment	1
20	107700-0020	3" Bore x 10" Storke Hyd Cylinder	1
**	107200-0532	Hydraulic Cylinder 3" Bore x 10" Stroke	1

**\*\*Check the Hydraulic cylinder before placing an order.**

# 11 PARTS

## 11.13.1 Transfer Auger - Lift and Swing Pedestal

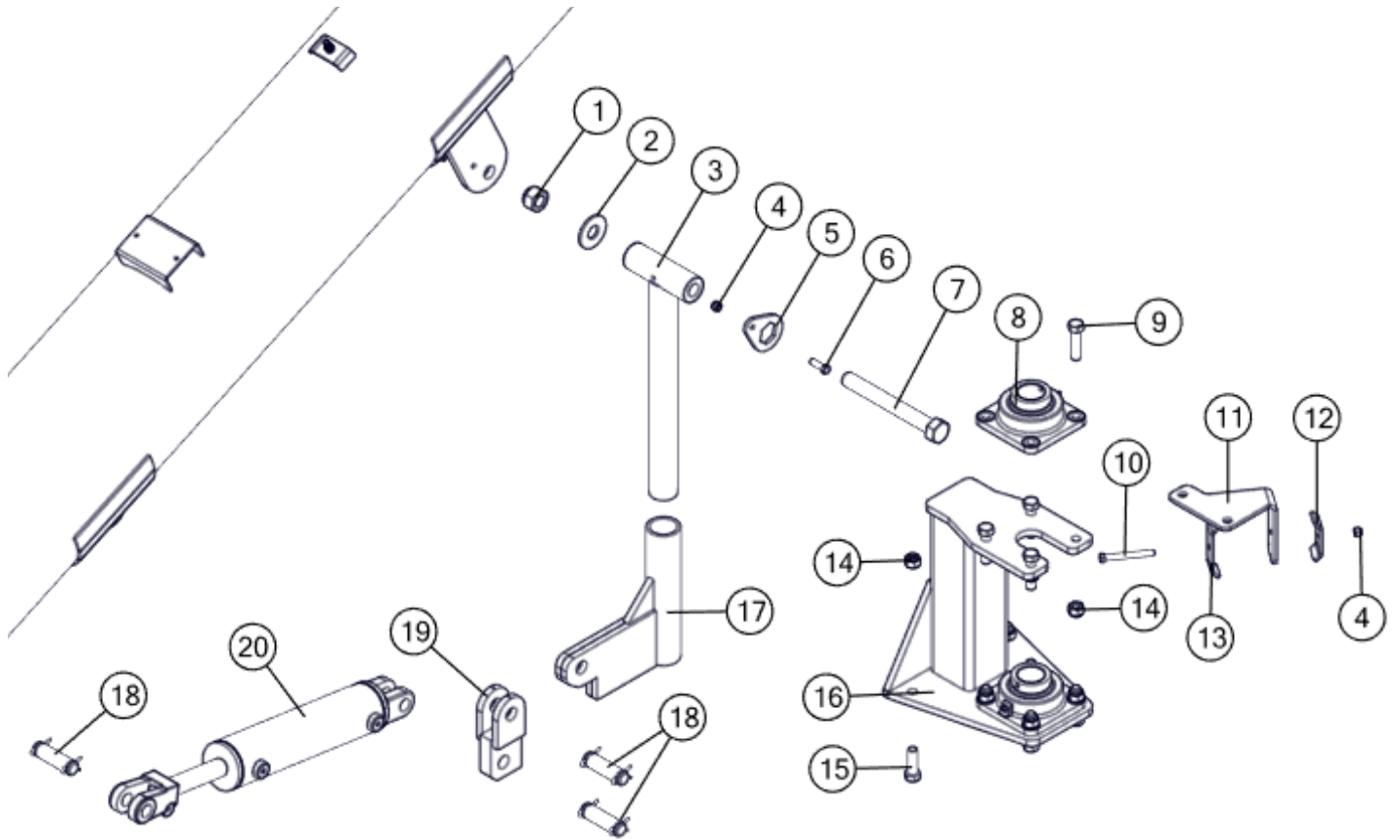

## 11 PARTS

### 11.13.2 Transfer Auger - Upper Section

REF #	PART #	DESCRIPTION	QTY
1	671300-0575.00	12" x 10' Transfer Auger Tube	1
2	470000-0214.00	Rubber Belting - 3/16" x 4"	1
3	167200-0652	Nyloc Nut - 3/8" NC Gr.5 PL	8
4	168000-0540	Flat Washer - 3/8" SAE	6
5	159300-0961	Hex Bolt - 3/8" NC x 1" Gr.5 PL	10
6	114000-0250	Bearing - 4-Bolt Flange 1-15/16" ID NTN (UELFU-1.15/16M)	1
7	159400-0427	Hex Bolt - 1/2" NC x 2" Gr.5 PL	2
8	671300-0324.00	Hydraulic Motor Mount Weldment	1
9	168000-0580	Flat Washer - 5/8" SAE PL	2
10	167200-0690	Nyloc Nut - 5/8" NC Gr.5 PL	6
11	111200-0026	Hydraulic Motor - 2000 Series 9.6cu.in. ORB	1
12	167200-0688	Nyloc Nut - 1/2" NC Gr.5 PL	2
13	471300-0293.00	Shield - 2000 Series Motor	2
14	168600-0071	Lock Washer - 3/8" PL	4
15	159400-0628	Hex Bolt - 5/8" NC x 2" Gr.5	4
16	480100-0722.01	Hose Clamp	2
17	129000-0514	Sprocket - 14 Tooth #60 x 1-1/4"	2
18	140100-0059	Chain - Double #60 - 14 pins, 14rollers, w/ connector	1
19	414000-0583.00	5/16" Keystock x 1-1/2"	1
20	172200-0790	Spring Pin - 5/16 x 2-1/2"	1
21	671300-0311.00	12" x 10' Auger Weldment	1

## 11 PARTS

### 11.13.2 Transfer Auger - Upper Section

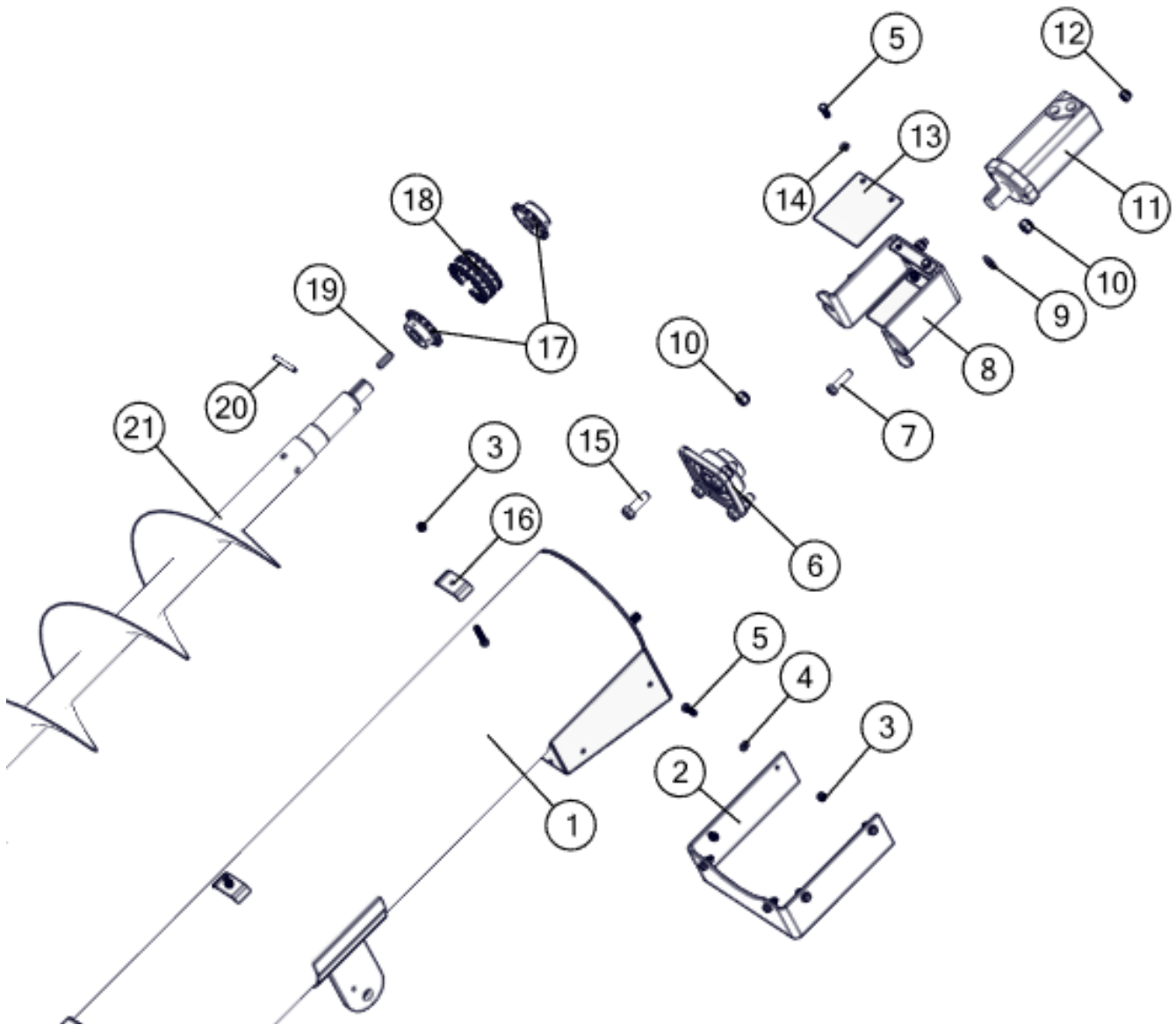

## 11 PARTS

### 11.13.3 Transfer Auger - Hopper Body

REF #	PART #	DESCRIPTION	QTY
1	167200-0652	Nyloc Nut - 3/8" NC Gr.5 PL	44
2	168000-0540	Flat Washer - 3/8" SAE	25
3	159300-0944	Hex Bolt - 3/8" NC x 3/4" Gr.5 PL	27
4	671300-0341.01	Safety Shield	1
5	471300-0681.00	Spray Cover - Hopper	1
6	161500-0500	Quick Pin - 3/8 x 2-1/2" PLT wire lock	1
7	470000-0255.01	Rubber Belting - 3/16" x 4"	1
8	671300-0659.00	Hopper Weldment - HD - 2020	1
9	100100-0423	Tire - 9" Smooth Solid	2
10	168000-0587	Flat Washer - 3/4" SAE PL	2
11	170000-0190	Cotter Pin - 3/16" x 1.5"	2
12	167200-0648	Nyloc Nut - 5/16" NC Gr.5 PL	3
13	114000-0144	1" - 3-Hole Cast Flange Bearing	1
14	163000-0299	Carriage Bolt - 5/16" x 1" Gr.5 PL	3
15	671300-0320.00	Auger Weldment	1
16	105000-0672	Hopper Drain Plug	1
17	470000-0225.00	End Yoke Series 14 1-1/4" Bore w/ Cross Hole	2
18	380000-0014	Series 14 Cross Bearing Kit - Transfer Hopper	1
19	159300-0961	Hex Bolt - 3/8" NC x 1" Gr.5 PL	21
20	168600-0071	Lock Washer - 3/8" PL	4
21	167000-0787	Hex Nut - 3/8" NC Gr.5 PL	6
22	671300-0293.00	Bushing Support Assembly	1
23	414000-0856.00	1/4" Keystock x 1-3/4"	2
24	159400-0005	Hex Bolt - 3/8" NC x 3" Gr.5 PL	2
25	471300-0729.00	Deflector Shield	1



# 11 PARTS

## 11.13.3 Transfer Auger - Hopper Body

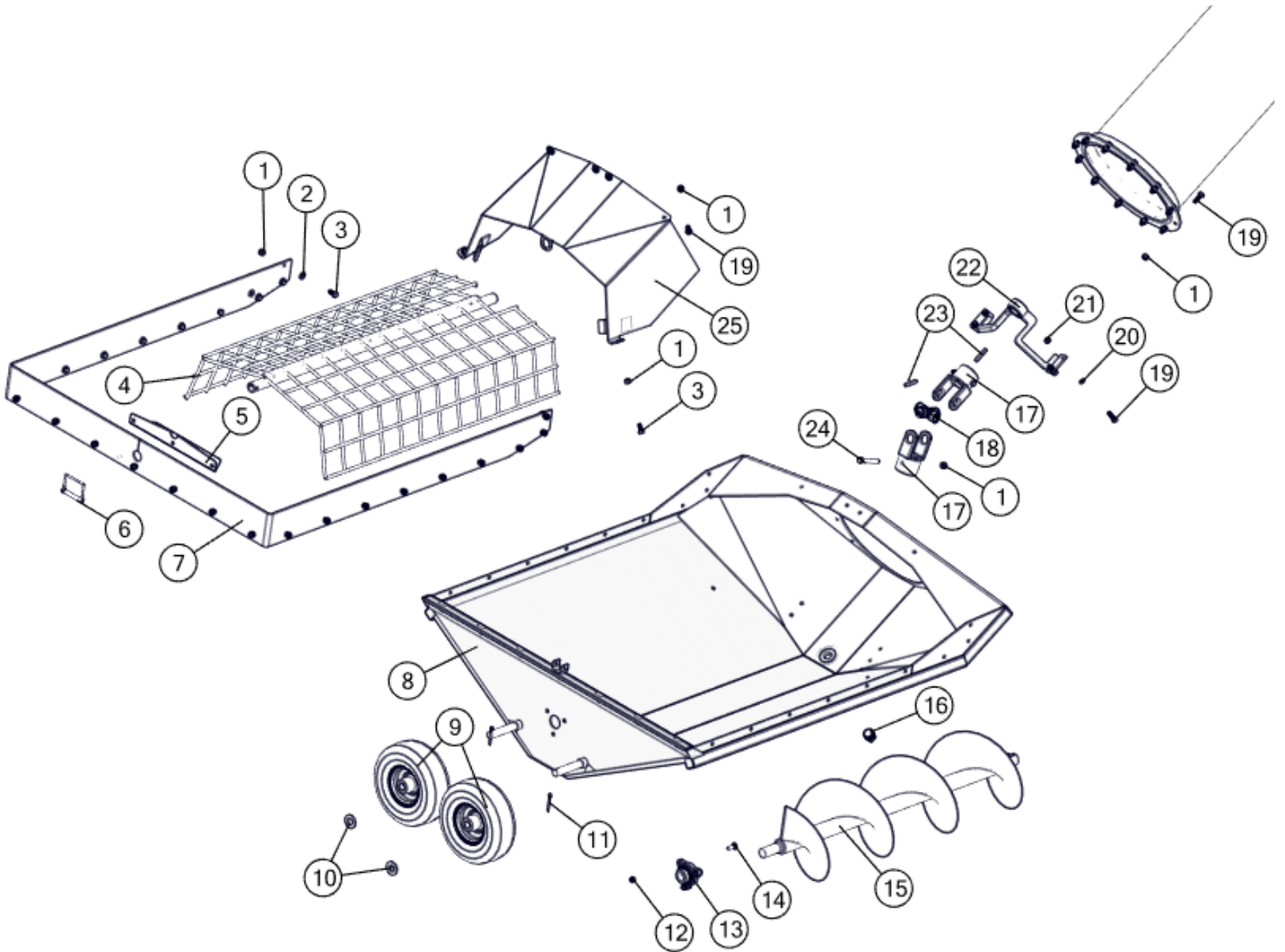

## 11 PARTS

### 11.14 Transfer Auger Hydraulics

#### 11.14.1 Transfer Auger Hydraulics - Lift

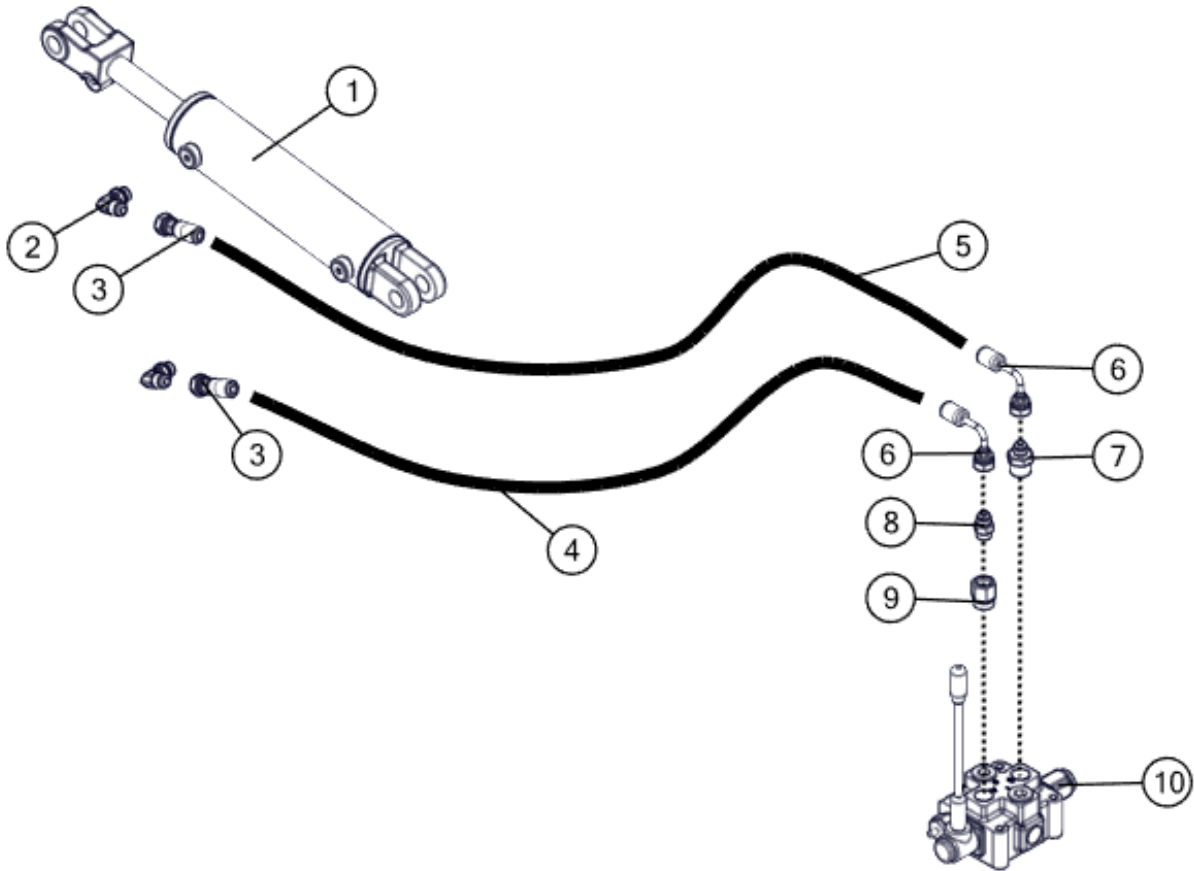

REF #	PART #	DESCRIPTION	QTY
1	107700-0020	3" Bore x 10" Stroke Hyd Cylinder	1
**	107200-0532	Hydraulic Cylinder 3" Bore x 10" Stroke	1
2	086800-0808	90° Elbow - #8 ORB x #8 JICM-sw	2
**	082500-0813	90° Elbow - 1/2" MNPT x #8 JICM	2
3	073600-0608	Hose End - 3/8" Dia x # 8 JICF-sw	2
4	H37500-0241	Hyd Hose 2WB Thin Cover 3/8" x 49"	1
5	H37500-0240	Hyd Hose 2WB Thin Cover 3/8" x 62"	1
6	071000-0605	Hose End - 3/8" Dia x #8 JICF-sw 90°	2
7	086400-0814	Hex Nipple - #12 ORBM x #8 JICM	1
8	081000-0108	Orifice Adapter - #8 ORBM x #8 JICM x .062"	1
9	085400-0952	Hex Reducer - #12 ORBM to #8 ORBF	1
10	110100-0423	1 Spool Valve Block - Q95	1

**\*\*Check the Hydraulic cylinder and ORB adapter before placing an order.**

**THIS PAGE INTENTIONALLY LEFT  
BLANK**

## 11 PARTS

### 11.14.2 Transfer Auger Hydraulics - Drive

REF #	PART #	DESCRIPTION	QTY
1	111200-0026	Hydraulic Motor - 2000 Series 9.6cu.in. ORB	1
2	086400-0820	Hex Nipple - #10 ORBM x #12 JICM	2
3	073800-0912	Hose End - 3/4" Dia x #12 90JICFsw	5
4	H75000-0200	Hydraulic Hose - 3/4" x 69"	2
5	073700-0212	Hose End - 3/4" Dia x #12 JICF-sw	3
6	110100-0402	Flow Control Valve - 3/4" Ports	1
7	110300-0032	Pressure Gauge - Vertical - 0 to 5000 psi	1
8	084900-0100	Tee Port Adaptor #12 JICM x #12 JICF x 1/4" FPT	1
9	082500-0825	90° Elbow - 3/4" MNPT x #12 JICM	1
10	082400-0820	Hex Nipple 3/4" MPT x #12 JICM	1
11	085100-0824	Tee - #12 JICM x #12 JICM x 3/4" MNPT	1
12	H75000-0241	Hyd Hose 2WB Thin Cover 3/4" X 72"	1
13	H75000-0240	Hyd Hose 2WB Thin Cover 3/4" X 201"	1
14	086400-0821	Hex Nipple - #12 ORB x #12 JICM	2
15	110100-0423	1 Spool Valve Block - Q95	1
16	H75000-0242	Hyd Hose 2WB Thin Cover 3/4" X 116"	1
17	071000-0910	Hose End - 3/4" Dia x 1/2" MNPT	2
18	104000-0610	Hydraulic - Q/C Male Poppet 1/2" FNPT	2

# 11 PARTS

## 11.14.2 Transfer Auger Hydraulics - Drive

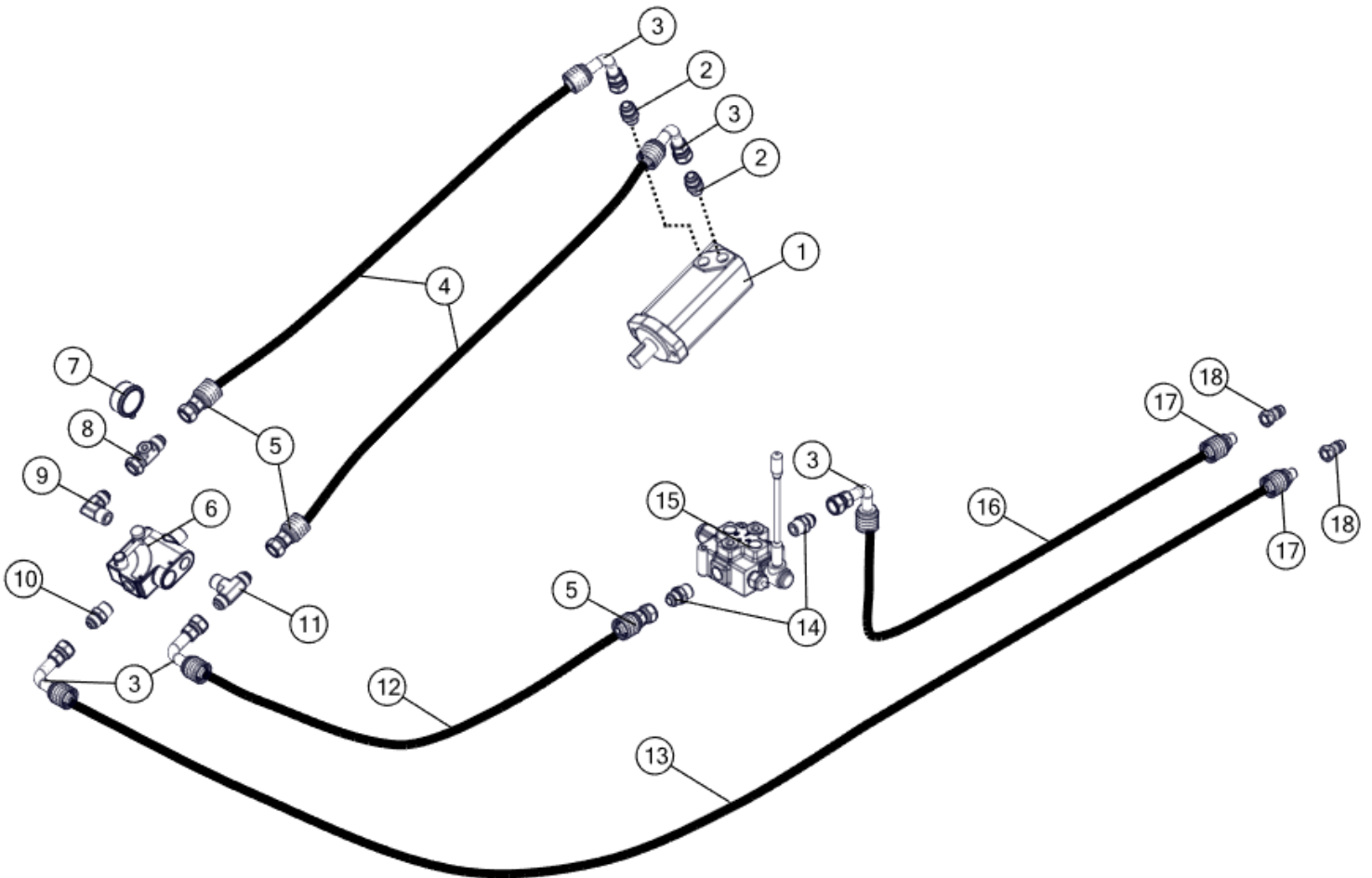

## 11 PARTS

### 11.15 Roll Bushing Assembly - B-Loc Bushing

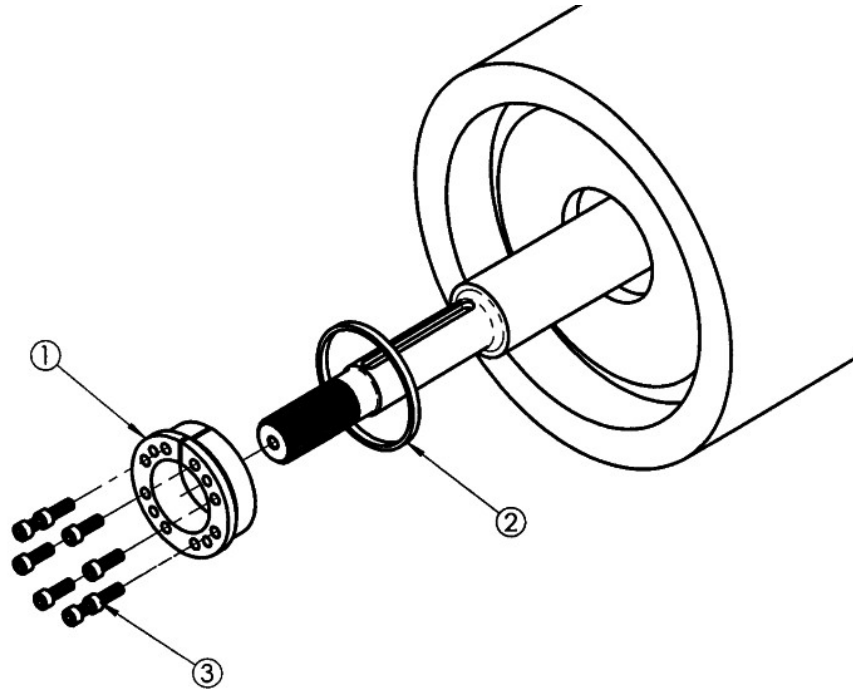

Roll Size Dia. x Length	[ #1 ] B-Loc Hub Part # & I/D	[ #2 ] B-Loc Spacer Ring & Size	[ #3 ] Socket Head Cap Screw (QTY) & Size	Tightening Torque (ft-lbs)
8-5/8" n x 10"	141000-0001 1-3/8"	N/A	(8) 6mm x 1.0 x 20mm	12
10-5/8" n x 16"	141000-0002 1-15/16"	N/A	(7) 8mm x 1.25 x 25mm	30
12 3/4" n x 12"	141000-0003 2-15/16"	141000-0006	(8) 10mm x 1.5 x 30mm	60
16" n x 12"	141000-0002 1-15/16"	N/A	(7) 8mm x 1.25 x 25mm	30
16" n x 18"	141000-0002 1-15/16"	N/A	(7) 8mm x 1.25 x 25mm	30
16" n x 24"	141000-0002 1-15/16"	N/A	(7) 8mm x 1.25 x 25mm	30
16" n x 24H	141000-0004 2-7/16"	N/A	(9) 8mm x 1.25 x 25mm	30
16" n x 30"	141000-0004 2-7/16"	N/A	(9) 8mm x 1.25 x 25mm	30
16" n x 30H	141000-0003 2-15/16"	141000-0006	(8) 10mm x 1.5 x 30mm	60
16" n x 36"	141000-0003 2-15/16"	141000-0006	(8) 10mm x 1.5 x 30mm	60
16" n x 48"	141000-0003 2-15/16"	141000-0006	(8) 10mm x 1.5 x 30mm	60
16" n x 60"	141000-0010 3-7/16"	N/A	(8) 10mm x 1.5 x 30mm	60

Locking screws, taper, shaft & bore contact areas should be clean and lightly oiled, all collar slits should be aligned.

**DO NOT** use Molybdenum Disulfide (e.g. Molykote, Never-Seize or similar lubricants) in any locking assembly.





Printed in Canada